

# TM 9-1240-285-35

DEPARTMENT OF THE ARMY TECHNICAL MANUAL

---

FIELD AND DEPOT MAINTENANCE MANUAL

## **TELESCOPE MOUNT M114 (T199)**

---

*HEADQUARTERS, DEPARTMENT OF THE ARMY*

18 JULY 1960

---



TECHNICAL MANUAL }  
 No. 9-1240-285-35 }

HEADQUARTERS,  
 DEPARTMENT OF THE ARMY  
 WASHINGTON 25, D.C., 18 July 1960

TELESCOPE MOUNT M114 (T199)

	Paragraphs	Page
CHAPTER 1 .	INTRODUCTION	
Section I.	General . . . . .	1-4      3
Section II.	Description and data . . . . .	5-7      5-8
CHAPTER 2 .	TOOLS AND EQUIPMENT . . . . .	8-11      10
3.	INSPECTION	
Section I.	General . . . . .	12-14    12, 13
Section II.	Inspection of telescope mount M114 (T199) in the hands of troops	15-19    13, 14
Section III.	Inspection of materiel received in field and depot maintenance shops . . . . .	20,21    14
CHAPTER 4 .	TROUBLESHOOTING . . . . .	22,23    15
5.	REMOVAL OF TELESCOPE MOUNT M114 (T199)	
Section I.	General . . . . .	24, 25    17
Section II.	Removal of telescope mount M114 (T199) . . . . .	26,27    17
CHAPTER 6 .	FIELD MAINTENANCE REPAIR	
Section I.	General . . . . .	28, 29    19
Section II.	Repair of telescope mount M114 (T199) . . . . .	30-35    19, 20
CHAPTER 7 .	REBUILD OF TELESCOPE MOUNT M114 (T119)	
Section I.	General . . . . .	36-40    21
Section II.	Removal of assemblies . . . . .	41-44    21-25
Section III.	Removal of subassemblies . . . . .	45-50    25,26
Section IV.	Rebuild of assemblies . . . . .	51-53    26-28
Section V.	Installation of subassemblies . . . . .	54-58    28
Section VI.	Installation of assemblies . . . . .	59, 60    28-30
Section VII.	Test and adjustment of telescope mount M114 (T199) . . . . .	61-67    30, 31
CHAPTER 8 .	FINAL INSPECTION . . . . .	68-70    33
9.	INSTALLATION OF TELESCOPE MOUNT M114 (T199)	
Section I.	Installation . . . . .	71, 72    34
Section II.	Adjustment . . . . .	73      34
CHAPTER 10 .	PROCESSING AND PACKAGING . . . . .	74      35
APPENDIX	REFERENCES . . . . .	36, 37
INDEX . . . . .		38



# CHAPTER 1

## INTRODUCTION

---

### Section I. GENERAL

#### 1. Scope

*a.* This manual is published for the information of personnel responsible for field and depot maintenance of telescope mount M114 (T199). These instructions contain information on maintenance which is beyond the scope of the tools, equipment, or supplies normally available to using organizations.

*b.* This manual contains a description of telescope mount M114 (T199). It also specifies troubleshooting procedures, disassembly, rebuild procedures, and assembly of telescope mount M114 (T199) peculiar to field and depot maintenance. The instructions in this manual are intended for maintenance specialists who have been thoroughly trained in maintenance practices.

*c.* The appendix contains a list of current references, including supply and technical manuals, forms, and other available publications applicable to telescope mount M114 (T199). The maintenance allocation chart is included in TM 9-2350-215-20. TM 9-1240-285-35P lists repair parts and special tools authorized to field and depot maintenance personnel.

*d.* Operation, lubrication, and all maintenance operations allocated to the operators in performing maintenance work within their scope for telescope mount M114 (T199) are contained in TM 9-2350-215-10. Organizational maintenance operations allocated to the organizational mechanic are contained in TM 9-2350-215-20.

*e.* This first edition is being published in advance of complete technical review. Any errors or omissions will be forwarded on DA Form 2028 direct to the Commanding Officer, Raritan Arsenal, Metuchen, New Jersey, ATTN: ORDJR-OPRA.

#### 2. Maintenance Allocation and Parts

*a.* Field maintenance responsibilities prescribed in this manual will apply as reflected in the maintenance allocation chart in TM 9-2350-

215-20 and as reflected by the allocation of repair parts and tools listed in TM 9-1240-285-35P.

*b.* Depot maintenance responsibilities will provide for complete rebuild of telescope mount M114 (T199) as reflected by the rebuild procedures prescribed in this manual for the purpose of rebuilding an unserviceable item.

*c.* The average time required to rebuild telescope mount M114 (T199) to place it in a serviceable condition is 7.0 man-hours of labor.

*d.* Depot maintenance parts are listed in TM 9-1240-285-35P, which is the authority for requisitioning replacements. Parts not listed therein but required by depot shops may be requisitioned and will be supplied, if available, when the need is substantiated. Requisitions for parts not listed in TM 9-1240-285-35P will contain a complete justification of requirements. Requisitions for assemblies will be held to a minimum. Whenever possible, rebuild of assemblies will be accomplished. When feasible, local fabrication may be required for those parts which cannot be supplied.

#### 3. Forms, Records, and Reports

*a. General.* Responsibility for the proper execution of forms, records, and reports rests upon the commanding officers of all units maintaining this equipment. However, the value of accurate records must be fully appreciated by all persons responsible for their compilation, maintenance, and use. Records, reports, and authorized forms are normally utilized to indicate the type, quantity, and condition of materiel to be inspected, to be repaired, or to be used in repair. Properly executed forms convey authorization and serve as records of work performed. The forms, records, and reports establish the work required, the progress of the work, and the status of this materiel upon completion of its repair.

*b. Authorized Forms.* The forms generally applicable to units maintaining this materiel are listed in the appendix. For instructions in

# REBUILD FLOW CHART

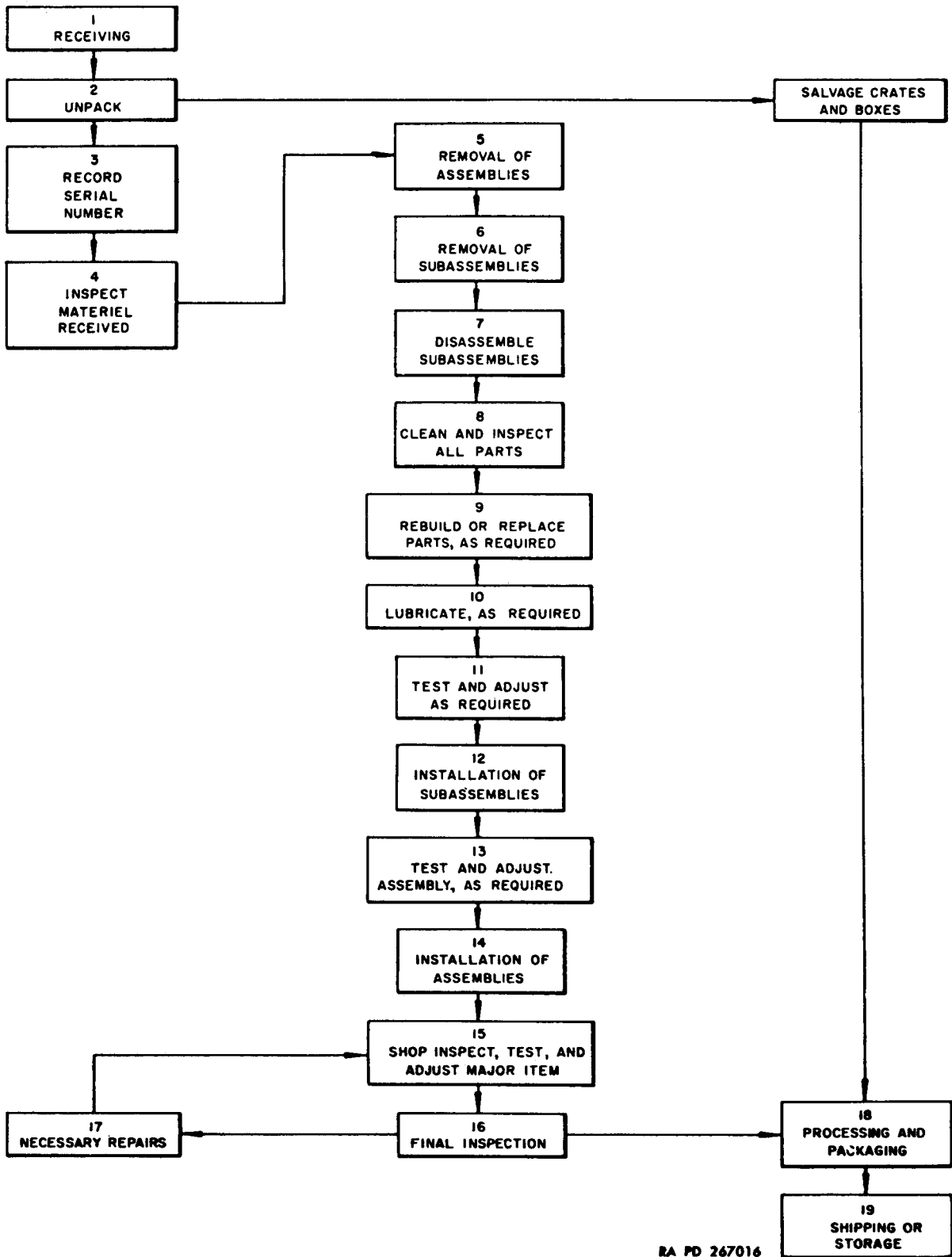

Figure 1. Rebuild flow chart

the use of these forms, refer to FM 9-3 and FM 9-4. For a listing of all forms, refer to DA Pam 310-2.

*c. Field Reports of Accidents.* The reports necessary to comply with the requirements of the Army safety program are prescribed in detail in AR 385-40. These reports are required whenever accidents involving injury to personnel or damage to materiel occur.

*d. Reports of Unsatisfactory Equipment or Materials.* Any deficiencies detected in the equipment covered herein, which occur under the circumstances indicated in AR 700-38, should be immediately reported in accordance with the applicable instructions in cited regulation.

4. Rebuild Flow Chart and Operations Route Sheet

*a. Rebuild Flow Chart.* The rebuild flow chart shown in figure 1 is to be used as a guide by depot maintenance organizations to assist in establishing a proper flow of work to assure most economical shop operation.

*b. Operations Route Sheet.* Table I, Operations Route Sheet for Telescope Mount M114 (T199), supplements the rebuild flow chart (fig. 1). The operation number corresponds to the number on the chart. Special tools and fixtures required for an operation are indicated opposite the operation. Detailed instructions for each of the operations are contained in the pertinent sections covering the specific operation.

**Table 1. Operations Route Sheet for Telescope Mount M114 (T199)**

Operation No.	Operation	Fixture	Tool
1	Receiving.		
2	Unpack.		
3	Record serial number.		
4	Inspect material received.		
5	Removal of assemblies.....		Spanner wrench (fig. 5)
6	Removal of subassemblies.		
7	Disassemble subassemblies.		
8	Clean and inspect all parts.		
9	Rebuild or replace parts, as required.		
10	Lubricate, as required.		
11	Test and adjust, as required.		
12	Installation of subassemblies.	.....	Spring wrench (fig. 4)
13	Test and adjust assembly, as required.		
14	Installation of assemblies.		Spanner wrench (fig. 5)
15	Shop, inspect, test, and adjust major item.		
16	Final inspection.....	mprovised testing device	Adapter torque wrench (fig. 6)
17	Necessary repairs.		
18	Processing and packaging.		
19	Shipping or storage.		

Section II. DESCRIPTION AND DATA

5. General

This section provides an overall description of the major item and includes a reference to the materiel with which it is used. It also describes the main components and how they tie into the complete telescope mount M114 (T199). The assemblies listed in table II constitute the major units of telescope mount M114 (T199).

**Table II. Main Assemblies of Telescope Mount M114 (T199)**

Identifying No.	Description
8574691	Base housing assembly
8574694	Holder assembly

6. Description

*a. General.* Telescope mount M114 (T199) (figs. 2 and 3) supports articulated telescope M105C for use as the secondary direct fire control system in the 105-mm gun full-tracked combat tank M60.

*b. Main Assemblies.* Telescope mount M114 (T199) consists of a base housing assembly, which is attached to the mounting of the tank and forms the basic structure, an adjustable slide assembly supported horizontally in the housing, and an adjustable holder assembly capable of vertical movement within the slide. Boresight knobs and scale dials for adjusting the telescope in deflection and elevation, and

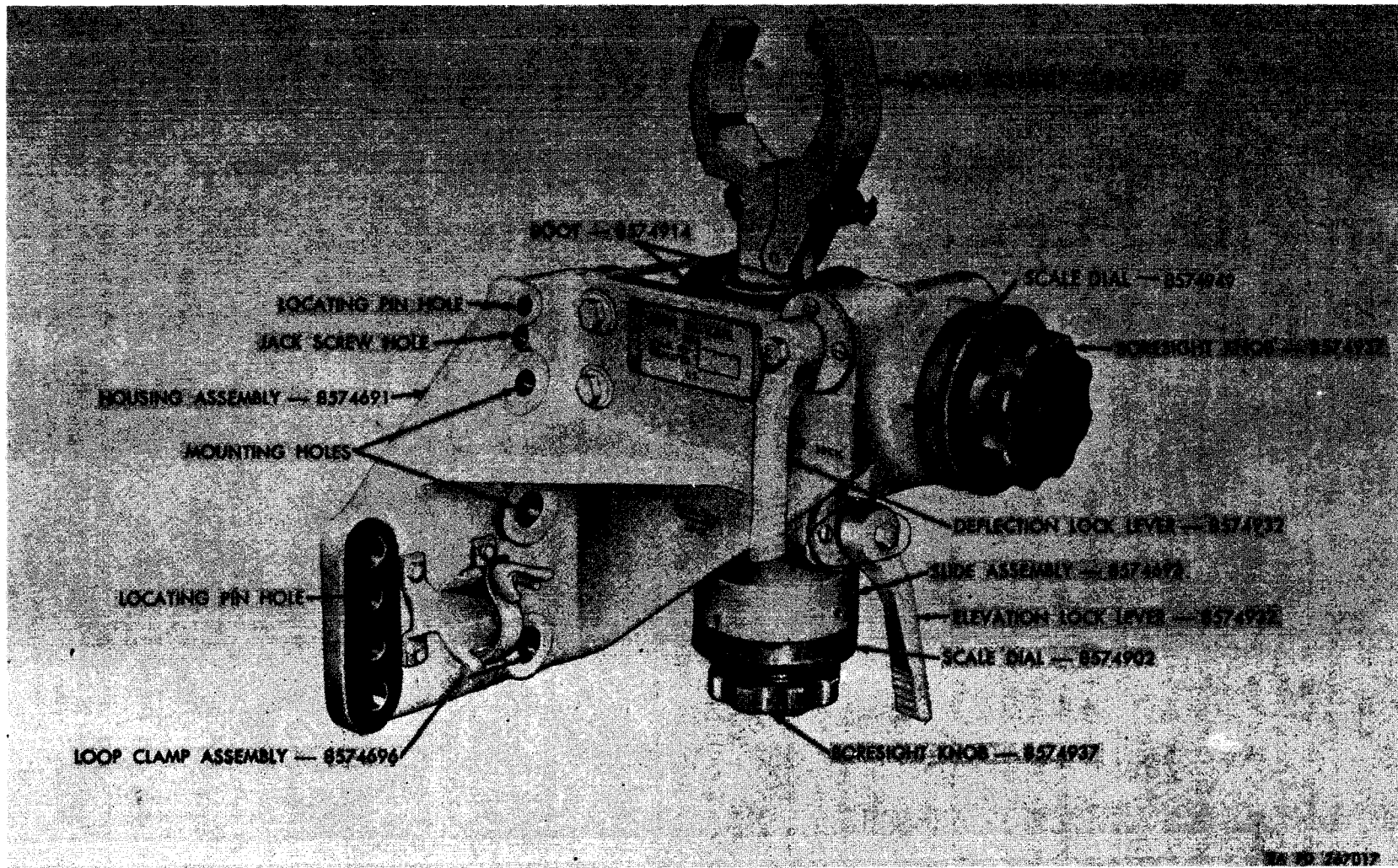

Figure 2. Telescope mount M114 (T199)  
 — front view.



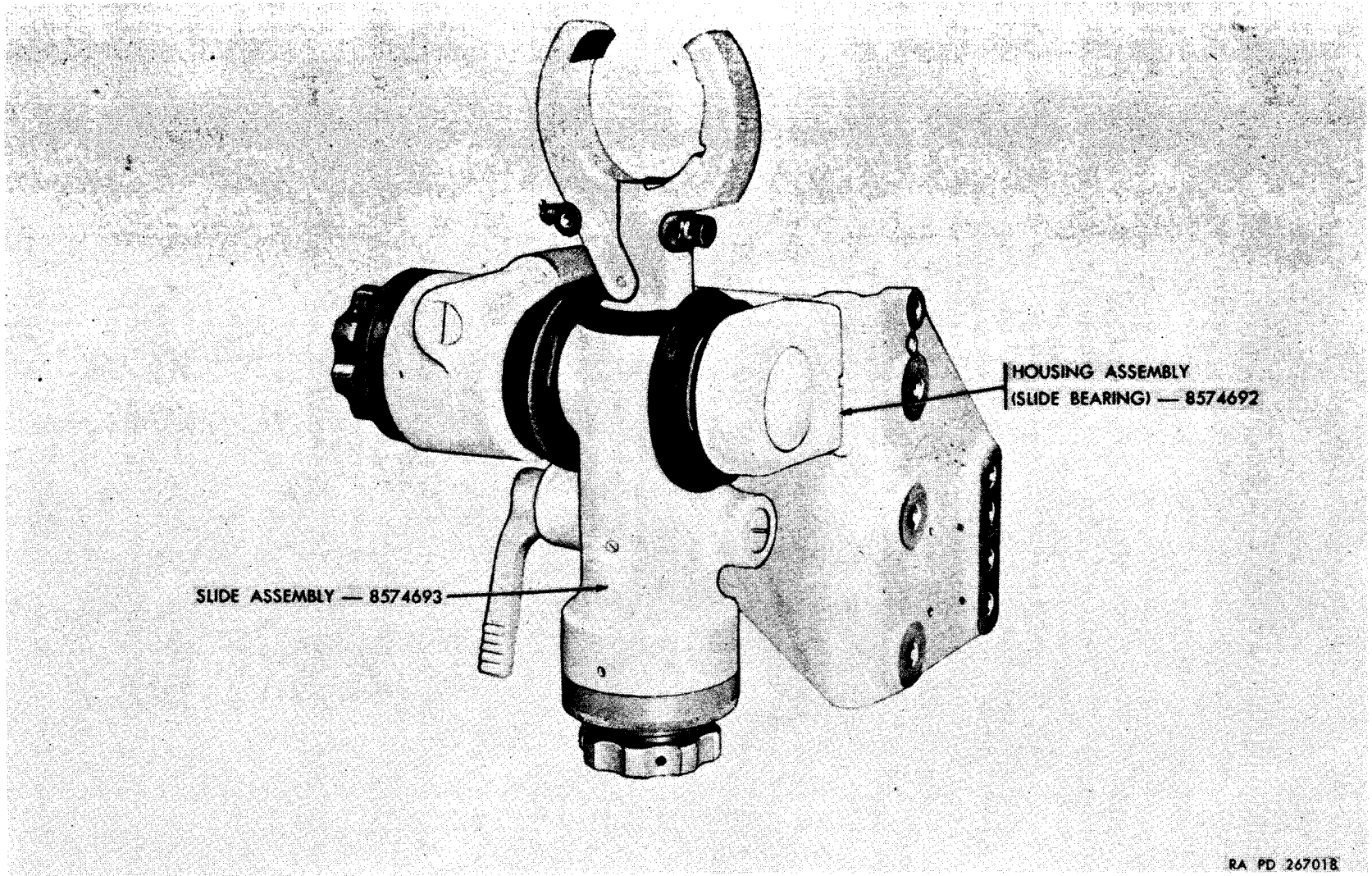

Figure 3. Telescope mount M114 (T199)  
— rear view.

RA PD 267018

locking mechanisms for holding the adjustments constitute the operating components of the telescope mount.

- (1) *Base housing assembly.* The housing assembly, attached to the tank mounting surface with five screws and two locating pins (fig. 2), is the major supporting member of the telescope mount. A slide bearing housing, attached to the base housing, provides a bearing for the left end of the slide assembly. An element of the housing projects outward from the base and incorporates a horizontal bearing in which one end of the slide assembly ((2) below) is mounted. The latter is capable of adjustment in deflection by virtue of its mounting between the housing bearing and a second bearing formed by the smaller housing. The adjustment is provided by a screw which is supported between two cylindrical roller bearings in the housing bore. The deflection adjusting screw has no axial movement but can be rotated by means of a knob fixed to its outer end. The screw engages an internal thread in the slide so that when the knob is rotated, the slide is moved in deflection. The loop clamp assembly (fig. 2) is provided to hold the instrument light.
- (2) *Slide assembly.* The slide is mounted in the base housing assembly ((1) above) and contains the body of the holder assembly. The holder is capable of vertical movement within the slide, providing adjustment in elevation. The elevation adjusting screw is supported within the slide bore and

its function is identical to that of the deflection adjusting screw ((1) above).

- (3) *Holder assembly.* The purpose of the holder is to provide a rigid clamp for the telescope and at the same time to permit adjustment of the latter in elevation. The holder is internally threaded to receive the elevation adjusting screw ((2) above). The top of the holder forms an adjustable telescope clamp.
- (4) *Scale dials and boresight knobs.* Two calibrated scale dials marked off with 1-mil graduations are connected to the boresight knobs that are used to adjust the telescope in deflection and elevation. The scale dials indicate the scope of the adjustments and the deflection and elevation settings. If desired, each scale dial can be rotated independently of its associated boresight knob.
- (5) *Deflection and elevation lock levers.* These levers when turned clockwise actuate mechanisms which, respectively, clamp the slide and holder to hold the desired adjustments. The locking mechanisms are of the wedge and gib type and are located in the slide and the housing, respectively. They are appropriately marked on the housing.

## 7. Data

Length .....	10 in. (approx)
Height .....	13 in. (approx)
Width .....	10 in. (approx)
Deflection Adjustment .....	40 mils
Elevation Adjustment .....	40 mils
Weight .....	48 lb (approx)

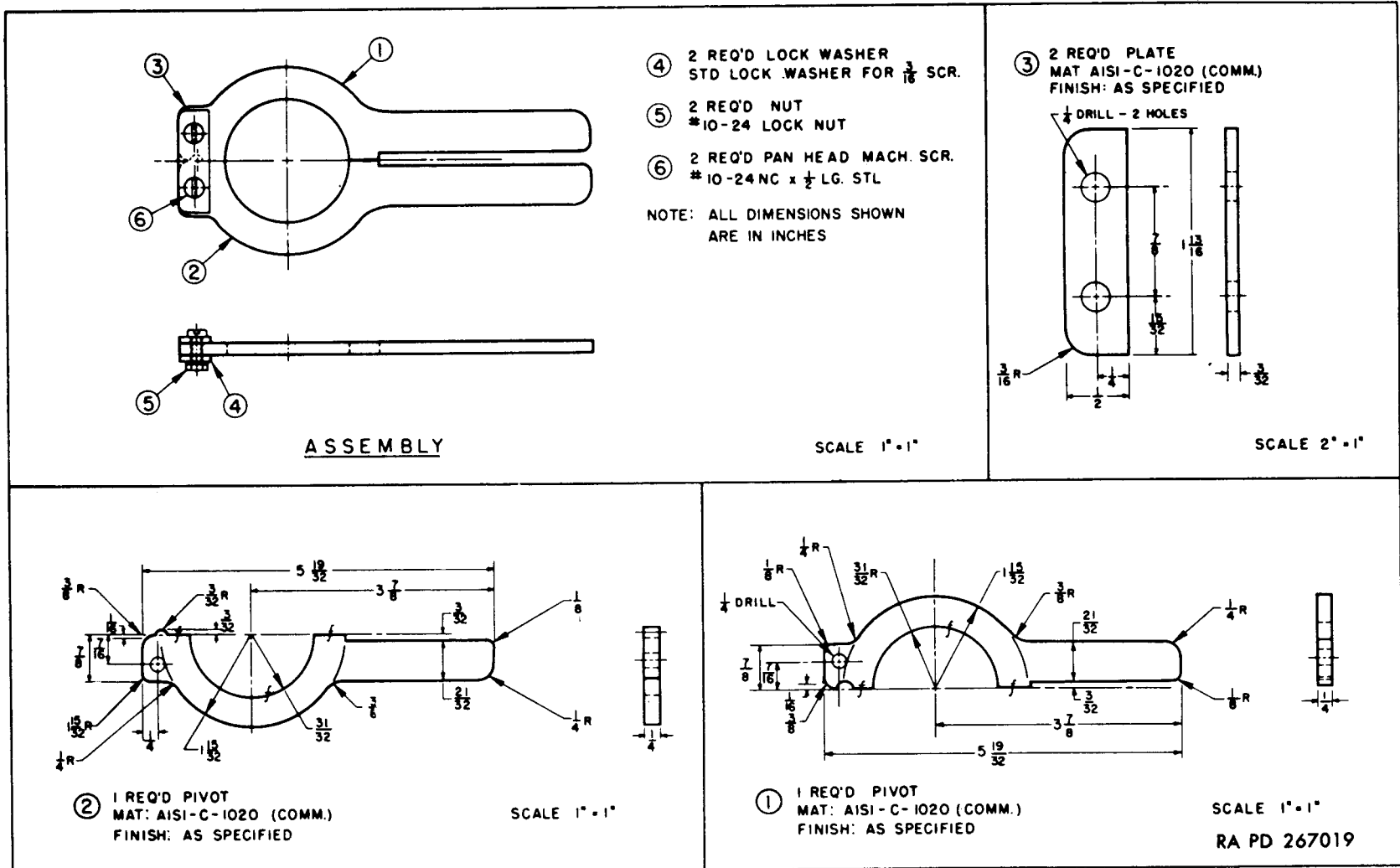

Figure 4. Spring wrench.

## CHAPTER 2 TOOLS AND EQUIPMENT

### 8. General

Tools and equipment over and above those available to the using organization are supplied to field maintenance units and depot shops for repair, adjustment, and rebuild of telescope mount M114 (T199).

### 9. Common Tools and Equipment

Standard and commonly used tools and equipment having general application to this materiel are authorized for issue by tables of allowances and tables of organization and equipment.

### 10. Special Tools and Equipment

No special tools and equipment are authorized or required.

### 11. Fabricated and Improvised Tools

*a. Fabricated Tools.* The tools listed in table III apply to field and depot shops performing repair or rebuild on telescope mount M114 (T199). Dimensional detail drawings (figs. 4, 5, and 6) are furnished herein to enable field maintenance units to fabricate these tools locally, if desired. These tools are considered essential for repair and will be replaced by the proper authorized tools as soon as practicable.

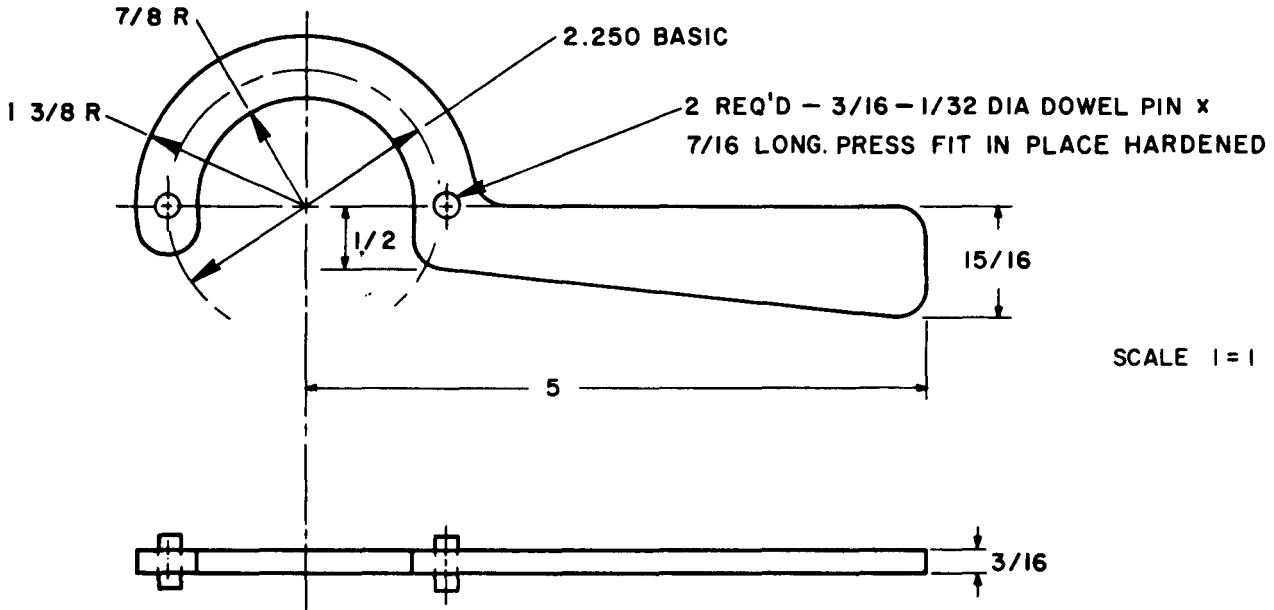

FILLETS & ROUNDS 1/4 R UNLESS  
OTHERWISE SPECIFIED

1 REQ'D WRENCH FOR RETAI ER ASS'Y  
MAT. AISI-C-1020 (COMM.)  
FINISH CASE HARDEN

NOTE: ALL DIMENSIONS SHOWN ARE IN INCHES

RA PD 267020

*Figure 5. Spanner wrench.*

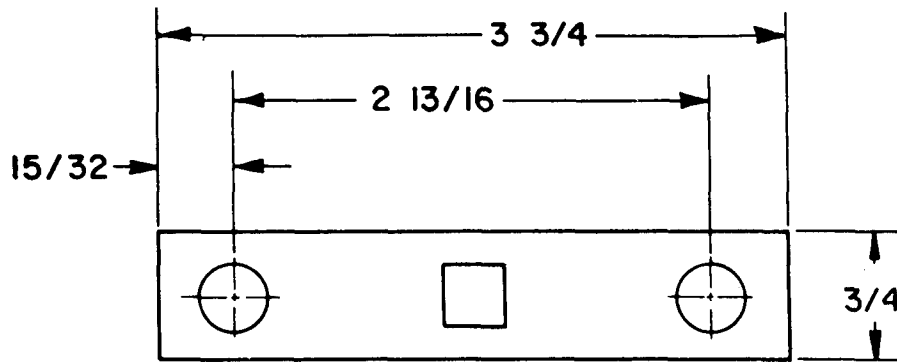

2 REQ'D. 3/8 DOWEL PINS 1 INCH LONG

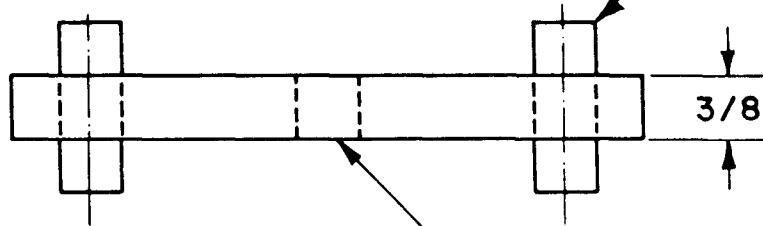

3/8 SQUARE HOLE  
(FOR 3/8 DRIVE TORQUE WRENCH)

NOTE: ALL DIMENSIONS SHOWN ARE IN INCHES

SCALE 1 = 1

RA PD 267021

Figure 6. Torque wrench adapter.

Table III. Fabricated Tools

Item	References		Use
	Fig.	Part.	
ADAPTER, torque wrench.....	6	79	Attach to standard in-lb torque wrench for testing boresight knobs and locks.
WRENCH, spanner.....	5	30c	For retainer 8574938.
WRENCH, spring .....	4	32b	To compress spring tension clip 8574779 during assembly.

b. *Improvised Tools.* The improvised testing device (fig. 13) is especially designed for inspection of telescope mount M114 (T199) at time of manufacture. This device may be fabricated for use in depot maintenance of the item,

but will not be available through supply channels. Drawings for this device are available and may be requisitioned from Frankford Arsenal, ATTN: ORDBA-3100.

## CHAPTER 3 INSPECTION

---

### Section I. GENERAL

#### 12. Scope

This chapter provides specific instructions for technical inspections by Ordnance maintenance personnel of telescope mount M114 (T199) in the hands of troops and when received for repair or rebuild in field and depot maintenance shops. It defines initial inspection of materiel when received for repair or rebuild by field and depot maintenance units, in-process inspection during repair or rebuild, and final inspection after repair and rebuild has been completed. The spot-check and command maintenance inspections performed by Ordnance field maintenance personnel are also defined.

#### 13. Purpose

##### *a. In the Hands of Troops.*

- (1) Insure that preventive maintenance services are being performed and are effective.
- (2) Ascertain the serviceability, completeness, or readiness of Ordnance materiel in the hands of troops.
- (3) Render any necessary assistance to the using organization.
- (4) Provide instructions for organizational supply and maintenance.
- (5) Determine the most prevalent deficiencies in maintenance of materiel.
- (6) Anticipate unusual supply demands.
- (7) Make a record of conditions of materiel in the hands of troops.

##### *b. In the Repair Shops.*

- (1) Determine the nature of the required repair.
- (2) Determine the extent of repair required to return the materiel to serviceability in order that its disposition may be planned.
- (3) Assure that work in process is being performed properly.
- (4) Insure that work performed complies fully with approved standards.

#### 14. Categories of Inspection

In general, five categories of inspection are performed by Ordnance maintenance personnel.

*a. Spot-Check Inspection.* This is a periodic inspection performed on only a percentage of materiel in the hands of troops by a contact party of field maintenance personnel to determine the adequacy and effectiveness of organizational supply and maintenance.

*b. Command Maintenance Inspection.* Command maintenance inspections will be performed annually by field maintenance personnel. The purpose of the inspection is to ascertain the serviceability of equipment, to predict maintenance and supply requirements, and to determine the adequacy of facilities and effectiveness of procedures. Information obtained during the inspection should indicate future requirements for depot maintenance and replacement, as well as disclose immediate needs for maintenance and application of modification work orders. During inspections, corrections of deficiencies will be made on the spot when practical. For additional information relative to these inspections and the forms to be used therewith, refer to AR 750-8.

*c. Initial Inspection.* This overall inspection is performed immediately on receipt of materiel in field maintenance shops or received for rebuild in depot maintenance shops. The field inspection determines the disposition of the materiel insofar as prompt repair when work can be accomplished by field maintenance units or evacuation to depot maintenance units when the work is more extensive. The depot inspection classifies materiel as scrap, reclaimable, or repairable and determines work required to return repairable materiel to serviceability.

*d. In-Process Inspection.* When performed by field Ordnance personnel, this inspection is accomplished in the process of repairing the materiel and its components. It insures that the workmanship is in accordance with approved methods and procedures and that deficiencies not disclosed by the initial inspection are found and corrected. In depot Ordnance maintenance shops, this inspection is performed by the floor

inspector in the process of rebuilding the materiel.

*e. Final Inspection.* This is an acceptance inspection performed by a final inspector, after

repair or rebuild has been completed, to insure that the materiel is acceptable for return to the user and is acceptable according to established standards.

## Section II. INSPECTION OF TELESCOPE MOUNT M114 (T199) IN THE HANDS OF TROOPS

### 15. General

This section provides specific instructions for the technical inspection by Ordnance field maintenance personnel of telescope mount M114 (T199) in the hands of troops. In general, if telescope mount M114 (T199) is complete and performs its intended function properly, if all modification work orders classified as urgent have been completed, and if all defects as disclosed by the inspection have been corrected, telescope mount M114 (T199) may be considered serviceable.

### 16. Forms and Reports

Authorized forms and reports for technical inspections by field maintenance personnel are listed in the appendix.

### 17. Modification Work Orders

All urgent modification work orders must have been applied. Check on application of all authorized modifications to see that no unauthorized alterations have been made or that work beyond the authorized scope of the unit is not being attempted. No modifications are required as of this printing. However, check the index in DA Pam 310-4 and the current modification work order files for any modification work orders promulgated subsequent to this printing.

### 18. General Inspection

*a.* Note general appearance as an indication of the condition of the materiel and the type of treatment it has received.

*b.* Check exterior of materiel and accessible parts for dented surfaces, bent or broken parts, missing parts, moisture and corrosion, and other evidence of damage or misuse which might indicate a need for repair. Examine dust-moisture seal boots for evidence of deterioration.

*c.* Inspect scale numbers, graduations, and lettering on nameplates and decals for legibility.

*d.* Inspect for bare spots or damaged finish which expose metal surfaces and lead to corrosion.

*e.* Adjustments and locks must operate smoothly without binding or rough motion.

*f.* The equipment must be free from dirt and grit.

*g.* Check appendix III in TM 9-2350-215-10 (operator's technical manual) for completeness of spare parts and equipment.

*h.* Check organizational spare parts and equipment for general condition and method of storage and procedures for obtaining replacements.

*i.* Investigate mechanical and functional difficulties that troops may be experiencing, and check for determinable causes such as inadequate design, poor workmanship or material, lack of knowledge, misinformation, neglect, and improper handling, storage, or preservation.

*j.* Instruct the using personnel in supply and preventive maintenance procedures if the need for such instruction is found necessary.

### 19. Performance Test of Telescope Mount M114 (T199)

*a.* The eyebolt of the loop clamp assembly must move freely on its pin and the wingnut must rotate freely on the threaded mating portion of the eyebolt. Check that the last thread of the eyebolt is sufficiently peened as to prevent removal of the wingnut.

*b.* Turn the deflection and elevation boresight locking levers to their extreme clockwise position. The deflection and elevation boresight knobs must be immovable when normal pressure is applied.

*c.* Test operation of the deflection and elevation boresight knobs by turning the knobs

clockwise and counterclockwise throughout their ranges. The motion should be smooth and even throughout. The knobs must have sufficient travel to allow their extreme graduation

marks to align with their respective indexes when the knobs are turned to their extreme clockwise and counterclockwise limits.

Section III. INSPECTION OF MATERIEL RECEIVED IN FIELD  
AND DEPOT MAINTENANCE SHOPS

20. General

Technical inspection performed by the Ordnance maintenance shop upon receipt of materiel turned in for repair or rebuild determines the cause of unserviceability, the amount of work required to return the materiel to serviceability, and the amount of supplies, parts, or assemblies necessary to accomplish the repairs.

nance field maintenance shop inspector consists of a check on the inspections performed in the hands of troops, and of determining additional defects not disclosed by the inspections performed in the hands of troops.

21. Inspection of Telescope Mount M114  
(T199)

*a.* The inspection performed by the Ord-

*b.* Refer to table IV, troubleshooting, for

corrective measures to be taken should they be encountered.



## CHAPTER 4

### TROUBLESHOOTING

#### 22. Purpose

Troubleshooting is a systematic isolation and remedy of malfunction and defective components by means of symptoms and tests. Close adherence to the procedures covered herein will materially reduce the time required to locate trouble and restore the equipment to normal operation.

**Caution: Operation of materiel without a preliminary examination can cause further damage to a disabled component. Be careful during inspection and troubleshooting, so that damage can be avoided.**

#### 23. Scope

This chapter covers troubleshooting which is peculiar to field and depot maintenance operations. Information in this chapter is to be used in conjunction with and as a supplement to the troubleshooting sections in TM 9-2350-215-20 (organizational maintenance manual). It provides a continuation of instructions when a remedy in the lower echelon technical manual refers to field or depot maintenance for corrective action.

*Table IV. Troubleshooting*

Malfunction	Probable cause	Corrective action
Deflection boresight adjusting mechanism binding (with deflection lock not set).	Screw threads of shaft burred	Chase threads or replace shaft (par. 53).
	Plug (locking mechanism) set too tight.	Loosen plug.
	Stud set too tight against wedge.	Increase thread engagement between stud and shaft.
	Roller bearings not rotating freely.	Clean and lubricate or replace bearings (pars. 44a and 59 b).
	Retainer set too tight.....	Loosen retainer.
	Shim too thick.....	Replace with a thinner shim (par. 53).
Deflection boresight adjusting mechanism too loose, causing free movement or lost motion.	Screw threads of slide burred or rusty.	Stone or clean with crocus cloth.
	Shim too thin.....	Replace with thicker shim (par. 53)
Elevation boresight adjusting mechanism binding (with elevation lock not set).	Retainer loose.....	Tighten retainer.
	Screw threads of shaft burred.....	Chase threads or replace shaft (par. 53).
	Plug (locking mechanism) set too tight.	Loosen plug.
	Stud set too tight against wedge.	Increase thread engagement between stud and shaft.
	Roller bearings not rotating freely.	Clean and lubricate or replace bearings (pars. 43c and 60d).
	Retainer set too tight.....	Loosen retainer.
Elevation boresight adjusting mechanism binding (with elevation lock not set) — continued.	Shim too thick .....	Replace with thinner shim (par. 53).
	Screw threads of holder burred or rusty.	Stone threads or clean with crocus cloth.
	Bearing surface of holder burred or rusty.	Carefully stone burs off or clean with crocus cloth.

*Table IV. Troubleshooting - Continued*

Malfunction	Probable cause	Corrective action
Elevation boresight adjusting mechanism too loose causing free movement or lost motion.	Shim too thin..... Retainer loose.....	Replace with thicker shim (par. 53). Tighten retainer.
Deflection locking mechanism does not secure deflection boresight adjusting mechanism.	Plug not bottomed..... Stud threads too deeply engaged in shaft. Lock lever loose on shaft. Cover loose.....	Screw in plug. Unscrew stud slightly. Tighten nut. Tighten cover screws.
Elevation locking mechanism does not secure elevation boresight adjusting mechanism.	Plug not bottomed..... Stud threads too deeply engaged in shaft. Lock lever loose on shaft..... Cover loose.....	Screw in plug. Unscrew stud slightly. Tighten nut. Tighten cover screws.

## CHAPTER 5

### REMOVAL OF TELESCOPE MOUNT M114 (T199)

---

#### Section I. GENERAL

##### 24. Scope

This chapter contains information for the guidance of Ordnance field maintenance personnel performing repair of telescope mount M114 (T199). It establishes a procedure for removing the mount from the installed position in the 105-mm gun full-tracked combat tank M60.

##### 25. Extent of Removal

If repair cannot be effected in the installed position, telescope mount M114 (T199) is to be removed for more extensive repair or adjustment. Where repair cannot be accomplished by field maintenance personnel, the telescope mount M114 (T199) is to be removed for return to Ordnance depot maintenance personnel.

#### Section II. REMOVAL OF TELESCOPE MOUNT M114 (T4 99)

##### 26. Procedure

*a.* Loosen wingnut of loop clamp assembly (fig. 2) and remove instrument light.

*b.* Remove five hexagon-head cap screws and five lock washers which attach telescope mount to 105-mm gun full-tracked combat tank M60 (fig. 7).

*c.* Insert jackscrews into jackscrew holes in housing (fig. 7) and tighten the screws until the telescope mount is lifted away from its base. Continue tightening the jackscrews until the telescope mount is lifted clear of the two locating pins.

**Caution: Support the mount from underneath as it is lifted away from the gun and off its**

**locating pins. Failure to do so will allow the mount to fall resulting in damage to the materiel and possible injury to personnel.**

*d.* Lift the mount away from the gun and remove the two jackscrews, and return them to stock for future use.

*e.* If the two locating dowel pins are to be replaced, remove them from the gun. Otherwise, they need not be removed.

##### 27. Flat-Rate Time

The average time required to remove telescope mount M114 (T199) from the tank is 0.1 man-hours of labor.

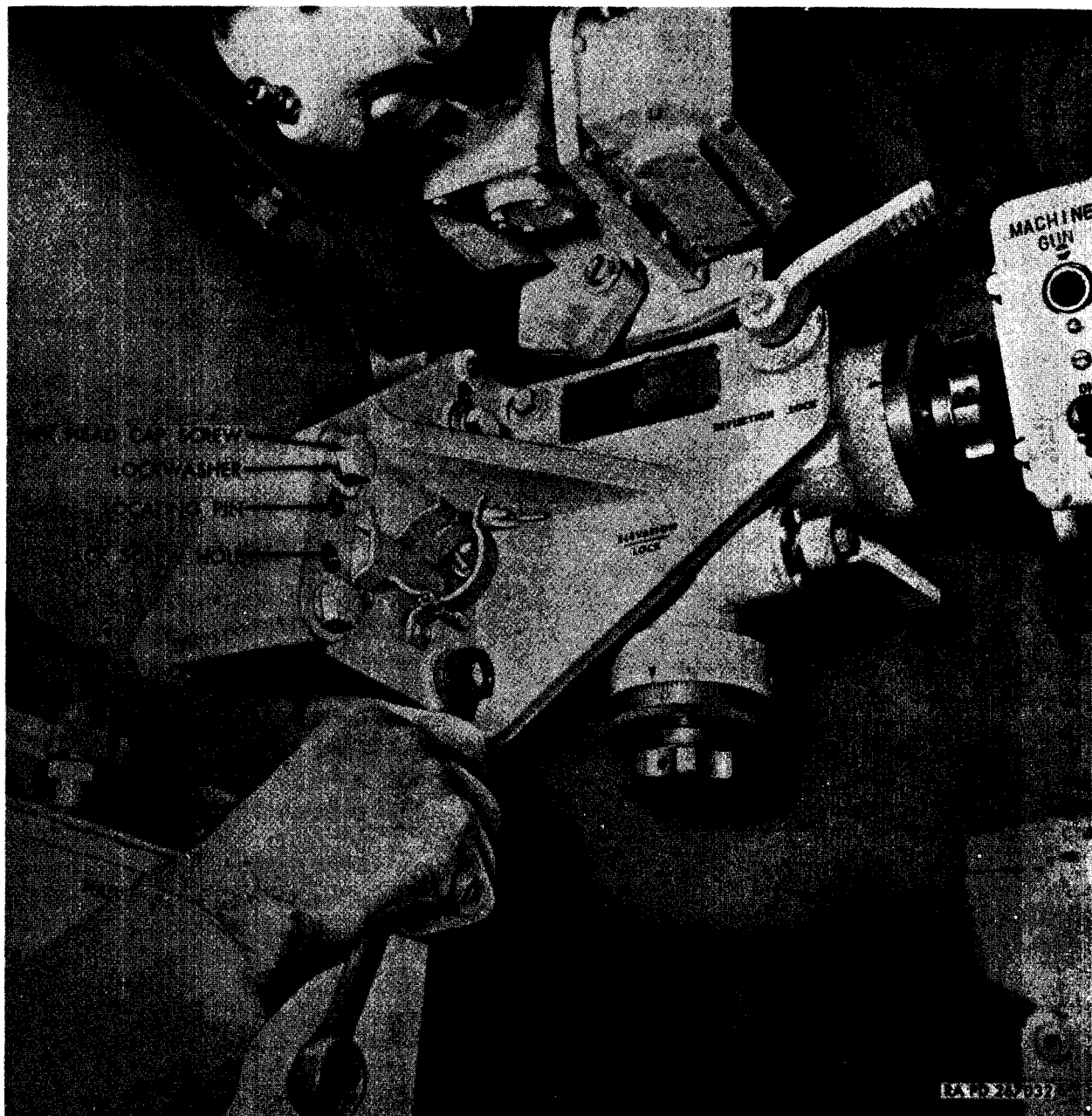

*Figure 7. Telescope mount M114 (T199) showing method of removal and installation.*

## CHAPTER 6

### FIELD MAINTENANCE REPAIR

---

#### Section I. GENERAL

#### 28. Scope

*a.* This chapter contains maintenance information covering telescope mount M114 (T199) that is within the scope of field maintenance personnel. The scope of field maintenance is determined by the listing of field maintenance parts in TM 9-1240-285-35P.

*b.* It is essential that field maintenance personnel remove only those components authorized for repair or replacement at the field maintenance level. In some cases, however, it may be necessary to remove satisfactorily operating assemblies or components or those which are not authorized for field maintenance

to accomplish the authorized maintenance. Any assembly or component so removed, should be installed immediately upon completion of the required maintenance.

#### 29. References

Organizational maintenance of telescope mount M114 (T199) is covered in TM 9-2350-215-20. General maintenance procedures are furnished in TM 9-254. Individual references to this manual are not made within this chapter and therefore, it is important that personnel become familiar with the content of TM 9-254.

#### Section II. REPAIR OF TELESCOPE MOUNT M114 (T199)

#### 30. Replacement of Dust-Moisture Seal Boot

*a.* Remove deflection locking mechanism (fig. 8).

- (1) Remove nut (A) and lock lever (B).
- (2) Remove four panhead screws (C), lockwashers (D), and cover (E).
- (3) Remove washer (F), shaft (H), with packing (G), and stud (J).
- (4) Remove plug (N) and, using a rod or punch, push out wedge (K).

*b.* Remove deflection boresight adjusting mechanism (fig. 10).

- (1) Drive out pin (A), loosen setscrew (C), and remove boresight adjusting knob (B) with spring (D) and scale dial (E).

*Note.* Do not separate knob and dial.

- (2) Remove two setscrews (X) securing retainer (G) and, using spanner wrench (fig. 5), remove retainer with packing (F) attached.
- (3) Remove washer (H), bearing (J), screw assembly (L) with packing (K) attached, and second bearing (J).

*c.* Remove two hexagon-head cap screws

(N,1), lockwashers (N,2), flat washers (N,3), and slide bearing housing (N,7).

*d.* Remove slide assembly (R) with holder assembly and elevation boresight adjusting mechanism attached.

*e.* Remove dust-moisture seal boots (Q).

*f.* Install new dust-moisture seal boots by fitting the smaller diameter flanges into the grooves of slide assembly (R).

*g.* Install slide assembly (R), with holder assembly and elevation boresight adjusting mechanism attached, into base housing assembly (N), fitting outer flange of boot into groove formed by ring (T) and base housing assembly (N).

*h.* Install slide bearing housing (N,7) over free end of slide assembly (R), fitting outer flange of boot into groove in slide bearing housing. Secure slide bearing housing to base housing with two  $\frac{1}{4}$  x 1 $\frac{1}{8}$  hexagon-head cap screws, (N,1),  $\frac{3}{8}$ -inch lock washers (N,2), and  $\frac{3}{8}$ -inch flat washers (N,3).

*i.* Install deflection boresight adjusting mechanism.

- (1) Lubricate bearing (J), screw assembly (L) with packing (K) attached, second bearing (J), and washer (H) lightly with aircraft and instrument grease 9150-576-4262 and install

- these parts in housing assembly (N).
- (2) Lubricate retainer (G) and, using spanner wrench (fig. 5), screw into base housing assembly (N) until retainer bottoms. Back retainer off one-quarter turn and secure with two No. 10 x ¼ hexagon-socket setscrews (X), applying sealing compound 8030-275-8110.
  - (3) Install boresight adjusting knob (B) with scale dial (E) and spring (D) attached, alining hole in knob with corresponding hole in shaft of screw assembly (L). Tighten setscrew (C) and install No. 3/0 x 1 7/16 tapered pin (A).
- j.* Install deflection locking mechanism (fig. 8).
- (1) Lubricate wedge (K) lightly with aircraft and instrument grease 9150-576-4262 and insert into housing assembly (GG), placing the flat surface formed by the right angle on the flat section of the slide assembly (P).
  - (2) Install plug (N) until it bottoms.
  - (3) Lubricate stud (J), shaft (H), packing (G), and washer (F) lightly with aircraft and instrument grease and install these parts in housing assembly (GG). Washer should be flush with face of housing. If not, screw shaft onto stud until this condition exists.
  - (4) Position cover (E) and secure with four No. 8 x 5/8 panhead screws (C) and No. 8 lockwashers (D), applying sealing compound 8030-275-8110.
  - (5) Place lock lever (B) on splined portion of shaft (H) and lock parts by turning lever clockwise. With parts locked, remove lever and install in the down position as shown on figure 2. Secure lever with hexagon nut (A).
31. Replacement of Elevation Boresight Knob and Spring
- a. Disassembly (fig. 10).*
- (1) Remove pin (A), setscrew (C), and knob (B) with spring (D) and scale dial (E) attached.
  - (2) Pull scale dial from knob to separate and release spring.
- b. Assembly (fig. 10).*
- (1) Using spring wrench (fig. 12), fit spring in annular groove in knob (B) and insert these parts in scale dial (E) (fig. 12).
  - (2) Position knob assembly on screw assembly (L), alining hole in knob with corresponding hole in shaft of screw assembly (L). Secure with No. 10 x ¾ setscrew and No. 3/0 x 1 7/16 tapered pin.
32. Replacement of Deflection Boresight Knob and Spring
- a. Disassembly (fig. 8).* Follow procedure in paragraph 31a, using parts (BB) through (FF).
- b. Assembly (fig. 8).* Follow procedure in paragraph 31b, using parts (BB) through (FF).
33. Replacement of Lock Levers
- a. Disassembly (fig. 8).* Remove nut (A) and lock lever (B).
- b. Assembly (fig. 8).* Position new lever on splined portion of shaft (H) and lock parts by turning lever clockwise. With parts locked, remove lever and install in the down position as shown on figure 2. Secure lever with hexagon nut (A).
34. Repair of Holder Assembly
- a. Disassembly (fig. 8).*
- (1) Remove cotter pin (M,1), setscrew (M,4), disk (M,3), and sleeve nut (M,2).
  - (2) Drive out pin (M,8).
- b. Assembly (fig. 8).*
- (1) Install new ¼ x 1 straight pin (M,8).
  - (2) Install new sleeve nut (M,2), disk (M,3), ¼ x ¼ hexagon-socket setscrew (M,4), and cotter pin (M,1).
35. Replacement of Loop Clamp Assembly
- a. Removal (fig. 11).* Remove four hexagon-head cap screws and loop clamp assembly.
- b. Installation (fig. 11).* Install new loop clamp assembly and secure with four hexagon head cap screws.

## CHAPTER 7

### REBUILD OF TELESCOPE MOUNT M114 (T199)

#### Section I. GENERAL

##### 36. Scope

This chapter contains specific maintenance instructions for the rebuild of telescope mount M114 (T199). In the following sections specific adjustments and rebuild procedures are described. The telescope mount is restored to a serviceable condition by disassembling its assemblies and subassemblies, inspecting and replacing or rebuilding parts using necessary machining operations, and finally, assembling and performing a final inspection. Unless obvious mechanical damage has occurred, replacement of parts will not be necessary.

*Note.* Manufactured assemblies should not be removed or disassembled if they are serviceable.

##### 37. Flat-Rate Time

The average time required to rebuild the complete telescope mount M114 (T199) is 7.0 man-hours.

##### 38. Cleaning

For general information regarding cleaning materials and services, refer to TM 9-254.

##### 39. Inspection

Inspection at the depot maintenance level consists of (1) a check on the inspections performed in the hands of troops and (2) the de-

termination of any additional defects not disclosed by the field inspection. For general inspection procedures, refer to paragraphs 12 through 21. Dimensional inspection is not required because the moving parts operate at low speeds through small ranges of motion and bearing surfaces are lightly loaded.

##### 40. Reclamation

*a. General.* For general reclamation techniques, refer to TM 9-254. Special reclamation instructions for specific components or parts are contained in pertinent paragraphs.

*b. Painting.* Paint all exposed surfaces so that the equipment will have the appearance of a new item. Refer to TM 9-2851 for detailed instructions on painting. Bearing surfaces, sliding surfaces, mating surfaces, screw threads, and all other critical surfaces must not show traces of paint or primer. Painting of the parts should be done at the most practicable stage of rebuild.

*c. Lubrication.* For parts requiring grease, use aircraft and instrument grease, 9150-576-4262, MIL-G-3278.

*d. Sealing.* For parts requiring sealing, use curing adhesive sealing compound, 8030-275-8110, MIL-S-11031.

#### Section II. REMOVAL OF ASSEMBLIES

##### 41. General

This section provides for disassembling telescope mount M114 (T199) into its main assemblies and the sequence of this operation.

##### 42. Removal of Assemblies

Table V establishes the main assemblies and the sequence of their removal from the housing assembly.

##### 43. Removal of Holder Assembly

*a. Remove elevation locking mechanism (fig. 8).*

(1) Remove nut (A) and lock lever (B).

*Table V. Main Assemblies and Sequence of Removal.*

Step	Description	Identifying No.	References		Man-hours
			Fig.	Par.	
1	Holder, assembly	8574694	8	44	2.0
2	Slide, assembly	8574693	9	43	1.5
3	Housing, assembly	8574691	9		

(2) Remove four panhead screws (C), lockwashers (D), and cover (E).

(3) Remove washer (F), shaft (H) with packing (G), and stud (J). Remove packing from shaft.

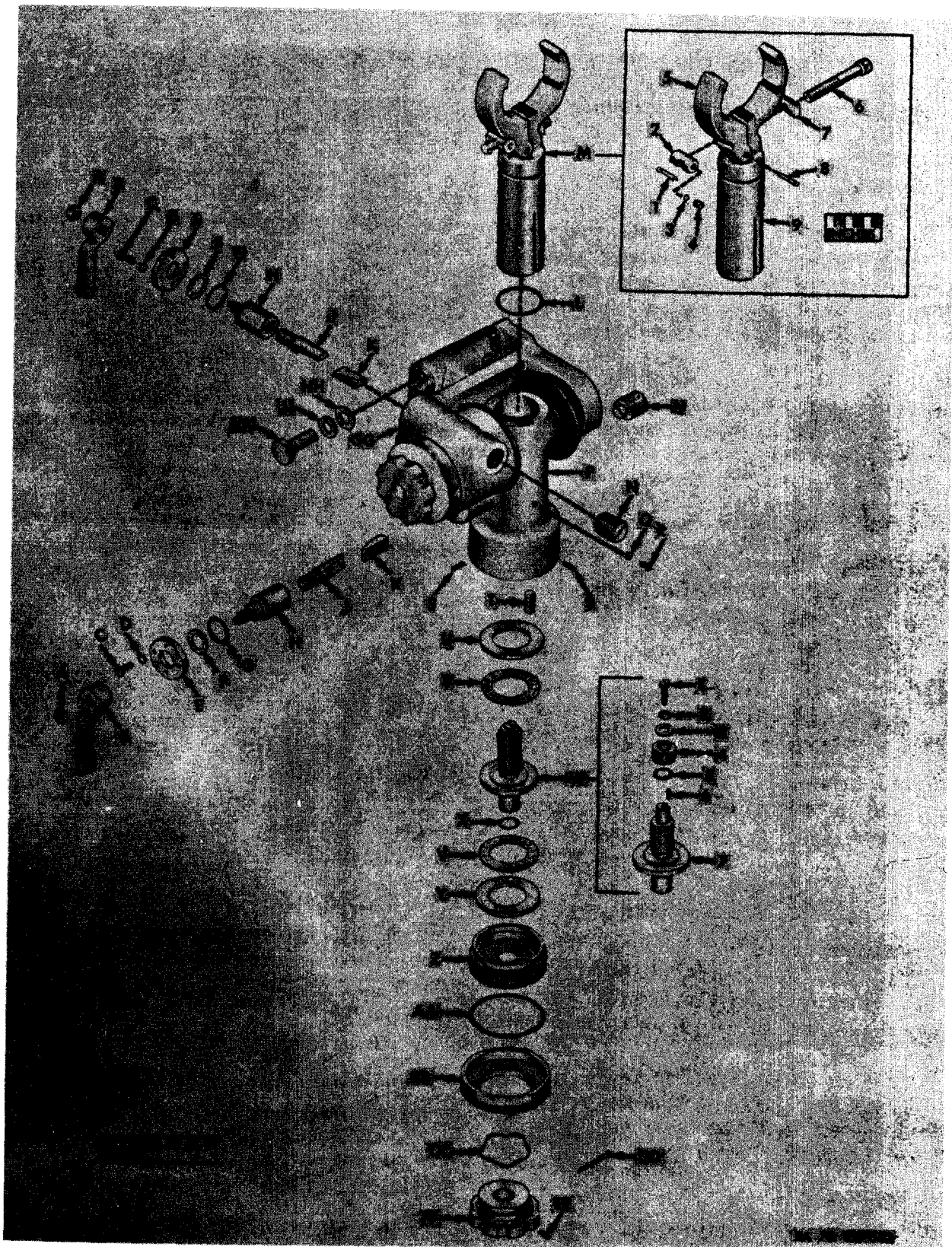

*Figure 8. Deflection and elevation locking mechanisms, elevation boresight adjusting mechanism, and holder-exploded view.*



- A—Nut 596507
- B—Lock lever 8574932
- C—No. 8 x  $\frac{5}{8}$  panhead screw MS35233-46
- D—No. 8 lockwasher MS35333-72
- E—Cover 8574883
- F—Flat washer 8574735
- G—Preformed packing 8574814
- H—Shaft 8574931
- J—Stud 8574882
- K—Wedge 8574872
- L—Preformed packing 8574832
- M—Holder assembly 8574694
  - 1—Cotter pin 220257
  - 2—Sleeve nut 8574944
  - 3—Disk 8574948
  - 4— $\frac{1}{4}$  x  $\frac{1}{4}$  hexagon-socket setscrew 587635
  - 5—Clamp 8574897
  - 6—Socket-head cap screw 8574943
  - 7—Pivot 8574946
  - 8— $\frac{1}{4}$  x 1 straight pin 544171
  - 9—Holder 8574935
- N—Plug 8574871
- P—Slide assembly 8574693
- Q—No. 4 lockwasher MS35333-19
- R—No. 4 x  $\frac{3}{8}$  panhead screw MS35233-15
- S—No. 10 x  $\frac{1}{4}$  hexagon-socket setscrew 585879
- T—Key 8574947
- U—Flat washer 8574836
- V—Cylindrical roller bearing 8574860
- W—Screw assembly 8574695
  - 1—No. 8 x  $\frac{5}{8}$  panhead screw MS35234-64
  - 2—No. 10 lockwasher MS35333-73
  - 3—Flat washer 8574699
  - 4—Sleeve 8574863
  - 5—Shim 8574755
  - 6—Key 8574749
  - 7—Shaft 8620410
- X—Preformed packing 8574780
- Y—Flat washer 8574838
- Z—Retainer 8574938
- AA—Preformed packing 8574835
- BB—Scale dial 8574902
- CC—Spring 8574779
- DD—No. 3/0 x 1 7/16 tapered pin 431647
- EE—No. 10 x  $\frac{3}{4}$  hexagon-socket setscrew 859354
- FF—Boresight adjusting knob 8574937
- GG—Housing assembly 8574691
- HH—Flat washer MS15795-318
- JJ— $\frac{1}{2}$ -inch lockwasher MS 35337-29
- KK— $\frac{1}{2}$  x 1  $\frac{1}{2}$  hexagon-head cap screw MS 35304-113

Figure 8-Continued.



Figure 9. Removal or installation of retainer.

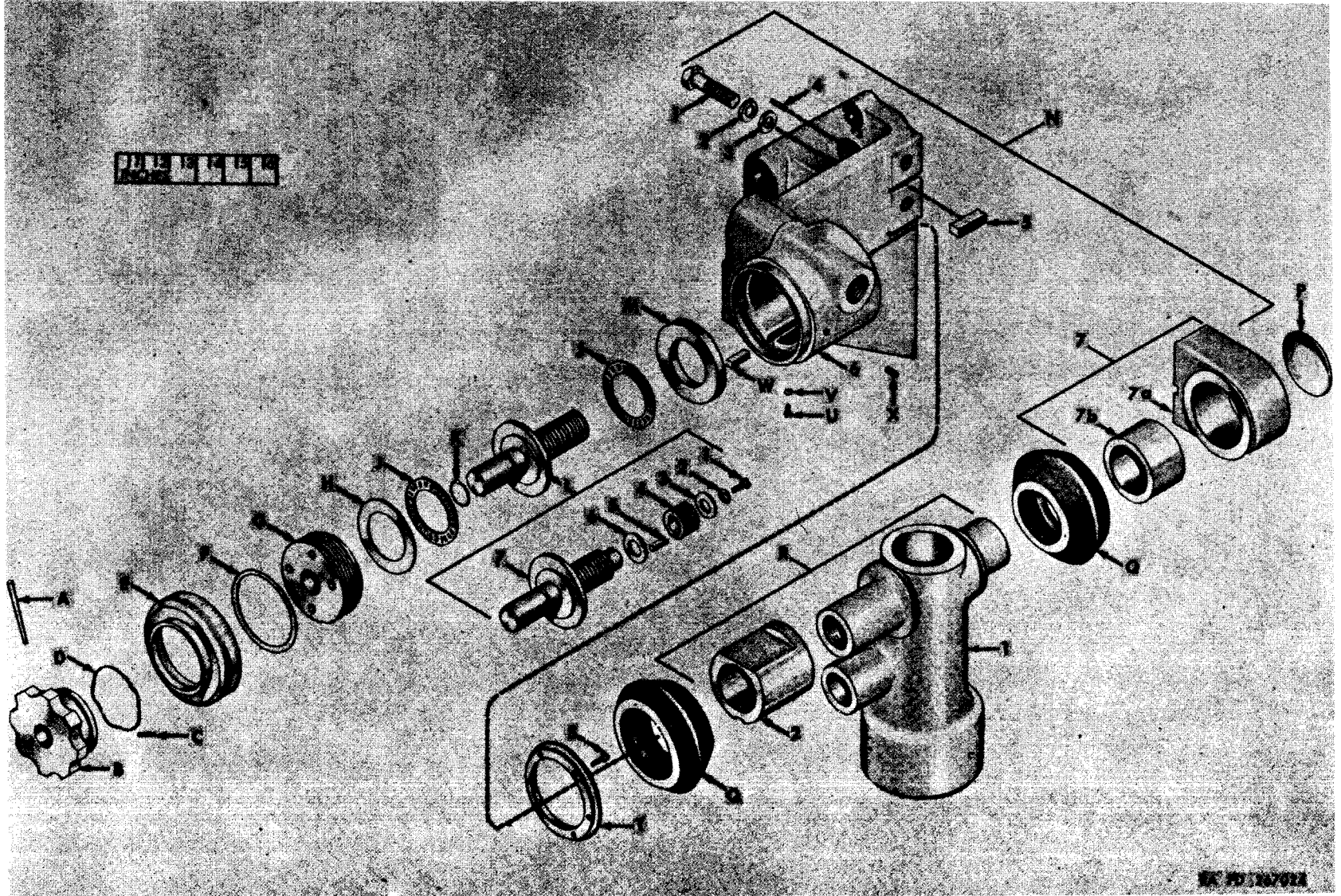

Figure 10. Deflection boresight adjusting mechanism and slide assembly—exploded view.

A—No. 3/0 x 1 7/16 tapered pin 431647  
 B—Boresight adjusting knob 8574937  
 C—No. 10 x 3/4 hexagon-socket setscrew 589354  
 D—Spring 8574779  
 E—Scale dial 8574949  
 F—Preformed packing 8574835  
 G—Retainer 8574938  
 H—Flat washer 8574838  
 J—Cylindrical roller bearing 8574860  
 K—Preformed packing 8574780  
 L—Screw assembly 8574695  
 1—No. 10 x 3/8 panhead screw MS35234-64  
 2—No. 10 lockwasher MS35333-73  
 3—Flat washer 8574699  
 4—Sleeve 8574683  
 5—Key 8574738  
 6—Shim 8574755  
 7—Shaft 8620410  
 M—Flat washer 8574836  
 N—Housing assembly 8574691

1—3/8 x 1 1/2 hexagon-head cap screw MS35297-64  
 2—3/8-inch lockwasher MS35337-27  
 3—3/8-inch flat washer MS1579-314  
 4—No. 4 x 3/8 socket-head cap screw 59111  
 5—Key 8574738  
 6—Housing 8574939  
 7—Housing assembly 8574692  
 7a—Housing 8574896  
 7b—Bushing 8574759  
 P—Expansion plug 587957  
 Q—Boot 8574914  
 R—Slide assembly 8574693  
 1—Slide 8574940  
 2—Bushing 8574966  
 S—No. 4 x 3/8 fillister-head screw MS35249-22  
 T—Ring 8574767  
 U—No. 4 x 3/8 panhead screw MS35233-18  
 V—No. 4 lockwasher MS35333-19  
 W—Key 8574947  
 X—No. 4 x 1/4 hexagon-socket setscrew 585879.

Figure 10-Continued.

- (4) Remove plug (N) and, using a rod or punch, push out wedge (K).
- b. Remove deflection locking mechanism (fig. 8). Follow procedure for elevation locking mechanism (a above).
- c. Remove elevation boresight adjusting mechanism (fig. 8).
- (1) Drive out pin (DD) and remove setscrew (EE). Remove boresight knob (FF) with spring (CC) and scale dial (BB) attached.
  - (2) Pull knob from scale dial to separate and release spring.  
**Caution: Restrain spring when released to prevent loss or injury to personnel.**
  - (3) Remove two setscrews (S) in slide assembly (P).
  - (4) Using spanner wrench (fig. 5), remove retainer (Z) with packing (AA) attached (fig. 9). Remove packing from retainer.
  - (5) Remove flat washer (Y), bearing (V), screw assembly (W) with packing (X) attached, and second bearing (V).
  - (6) Remove flat washer (U).
  - (7) Remove holder assembly (M) with

packing (L) attached. Remove packing from holder.

- (8) Remove panhead screw (R), lockwasher (Q), and key (T) from slide assembly (P).

#### 44. Removal of Slide Assembly

a. Remove deflection boresight adjusting mechanism (fig. 10). Follow procedure for elevation boresight adjusting mechanism using parts (A) through (M) in figure 10 (par. 43c (1) through (6) and (8)).

b. Remove slide bearing housing assembly (fig. 10).

- (1) Remove two hexagon-head cap screws (N,1), lockwashers (N,2) flat washers (N,3), and slide bearing housing assembly (N,7) with expansion plug (P) from base housing (N,6).
- (2) Remove expansion plug from slide bearing housing.
- (3) Remove slide assembly (R) from base housing assembly (N).
- (4) Remove dust-moisture seal boots (Q).
- (5) Remove six fillister-head screws (S) and ring (T).
- (6) Remove socket-head cap screw (N,4) and key (N,5).

### Section III. REMOVAL OF SUBASSEMBLIES

#### 45. Sequence of Removal

Table VI prescribes the subassemblies to be removed and the sequence of their removal.

#### 46. Removal of Screw Assemblies

a. *Elevation Boresight Adjusting Mechanism.* The removal of the screw assembly was

Table VI. Removal of Subassemblies

Step	Description	Identifying No.	References		Flat-rate time
			Fig.	Par.	
1	Screw, assembly.....	8574695	8, 10	46	
2	Slide bearing, assembly.....	8574692	10	47	
3	Loop clamp, assembly.....	8574696	11	48	0.1 man-hour
4	Identification plate .....	8574895	11	49	0.1 man-hour
5	Decals .....	8574889, 8574953	11	50	0.1 man-hour

necessary during the removal of the holder assembly (par. 43c).

*b. Deflection Boresight Adjusting Mechanism.* The removal of the screw assembly was necessary during the removal of the slide assembly (par. 44a).

47. Removal of Slide Bearing Housing Assembly

The removal of the slide bearing housing assembly was necessary during the removal of the slide assembly (par. 44 b).

48. Removal of Loop Clamp Assembly

Remove four screws that secure loop clamp assembly (fig. 11) to housing assembly. Remove loop clamp assembly.

49. Removal of Identification Plate

Remove four screws that attach identification plate (fig. 11) to housing assembly. Remove identification plate.

50. Removal of Decals

Remove DEFLECTION LOCK and ELEVATION LOCK decals (fig. 11).

Section IV. REBUILD OF ASSEMBLIES

51. Rebuild of Holder Assembly

*a. Disassembly (fig. 8).*

- (1) Remove cotter pin (M,1), setscrew (M,4), and disk (M,3) located under setscrew.
- (2) Remove socket-head cap screw (M,6) from sleeve nut (M,2).
- (3) Remove pivot (M,7) from socket-head cap screw (M,6).
- (4) Drive out pin (M,8) to release clamp (M,5) from holder (M,9).

*Note.* Wire clamp and holder together to assure assembly of same parts. These parts are machined as one unit and are not interchangeable between mounts.

*b. Cleaning, Inspection, and Reclamation.*

- (1) *Cleaning.* Refer to paragraph 38.
- (2) *Inspection.* Refer to paragraph 39.
- (3) *Reclamation.* Refer to paragraph 40.

*c. Rebuild Standards.* No rebuild standards are required.

*d. Assembly (fig. 8).*

- (1) Position clamp (M,5) on holder (M,9) and secure with ¼ x 1 straight pin (M,8). Stake pin in place.

- (2) Place pivot (M,7) on socket-head cap screw (M,6) and insert screw through upper part of holder (M,9).

- (3) Hold sleeve nut (M,2) in position and thread in socket-head cap screw (M,6).

- (4) Lock sleeve nut in place by installing disk (M,3), ¼ x ¼ hexagon-socket setscrew (M,4), and cotter pin (M,1).

*e. Tests and Adjustments.* No tests and adjustments are required.

52. Rebuild of Slide Assembly

*a. Disassembly (fig. 10).* Sleeve bushing is pressed on. Do not remove bushing from slide unless replacement is necessary.

*b. Cleaning, Inspection, and Reclamation.*

- (1) *Cleaning.* Refer to paragraph 38.
- (2) *Inspection.* Refer to paragraph 39.
- (3) *Reclamation.* Because wear of parts is negligible, reclamation is not required.

*c. Rebuild Standards.* Rebuild standards shall be in accordance with F8574693, which may be requisitioned from Frankford Arsenal, ATTN: ORDBA-3100.



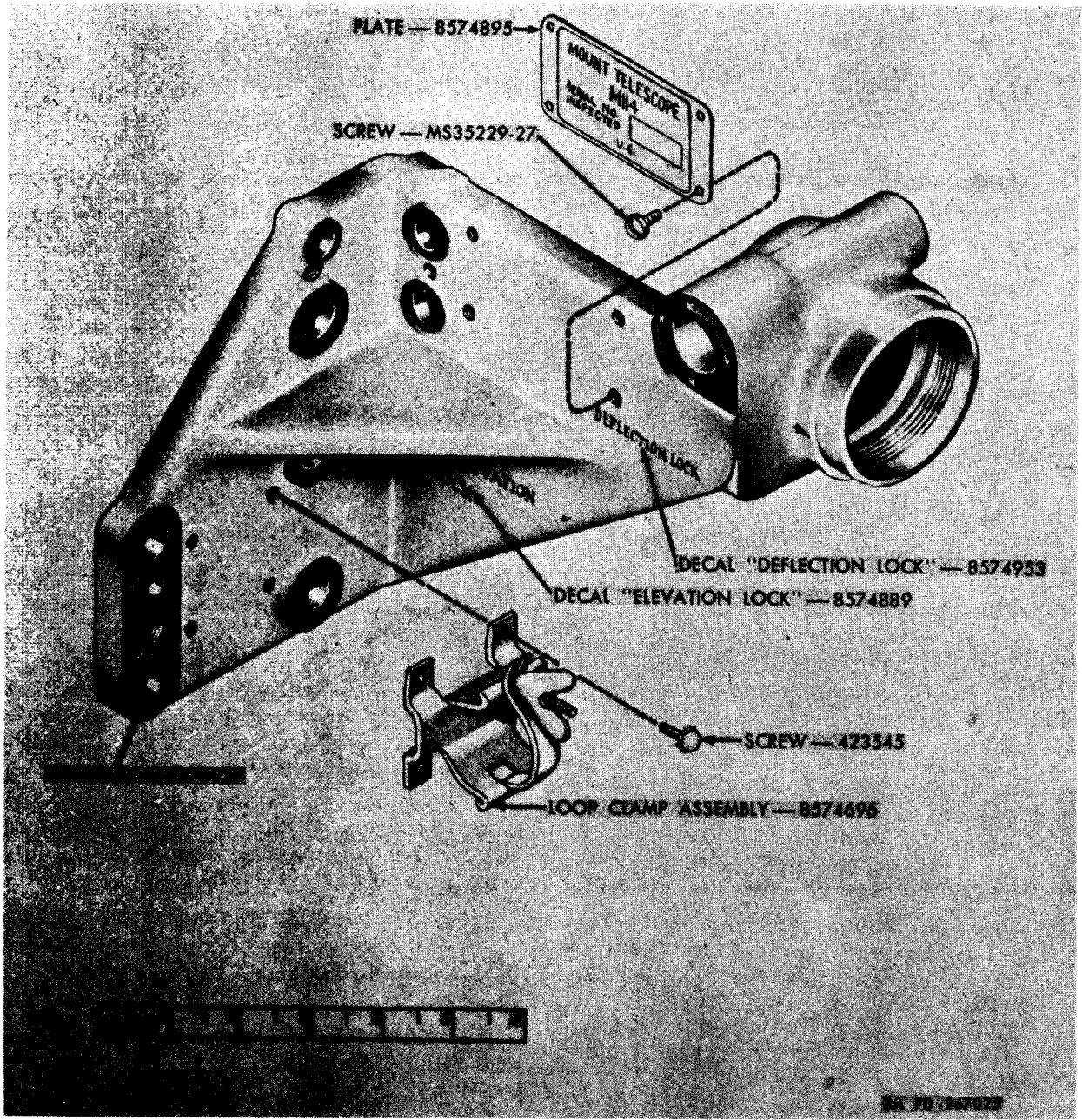

Figure 11. Housing and loop clamp assembly.

*d. Assembly (fig. 10).* If replacement of sleeve bushing is necessary, press on new bushing and machine in accordance with F8574693 (c above).

*e. Tests and Adjustments.* No tests and adjustments are required.

#### 53. Rebuild of Screw Assemblies

*a. Elevation Boresight Adjusting Mechanism (fig. 8).*

(1) *Disassembly.* Remove panhead screw (W,1), lockwasher (W,2), flat washer (W,3), sleeve (W,4), key (W,6) and shim (W,5) from shaft (W,7).

(2) *Cleaning, inspection, and reclamation.*

*(a) Cleaning.* Refer to paragraph 38.

*(b) Inspection.* Refer to paragraph 39.

*(c) Reclamation.* Refer to paragraph 40.

(3) *Rebuild standards.* No rebuild standards are required.

(4) *Assembly.* Install shim (W5) key (W,6), sleeve (W,4), flat washer (W,3), and No. 10 lock washer (W,2) on shaft (W,7) and secure with No. 10 x 5/8 panhead screw (W,1).

*Note.* Thickness of shim determines the amount of backlash of the boresight knob. Use a shim of the same thickness as the one previously used.

(5) *Tests and adjustments.* Test and adjustment of the screw assembly is performed after assembly of the complete telescope mount (pars. 61 through 67).

*b. Deflection Boresight Adjusting Mechanism (fig. 10).* Follow procedure for elevation boresight adjusting mechanism using parts (L,1) through (L,7) in figure 10 (a above).

### Section V. INSTALLATION OF SUBASSEMBLIES

#### 54. Installation of Decals

Install DEFLECTION LOCK and ELEVATION LOCK decals in accordance with printed instruction on each decal (fig. 11).

#### 55. Installation of Identification Plate

Position identification plate on housing assembly and secure with four No. 6 x 5/16 panhead screws (fig. 11).

#### 56. Installation of Loop Clamp Assembly

Position loop clamp assembly on housing assembly and secure with four No. 10 x 3/8 hexagon-head screws with assembled washers (fig. 11).

#### 57. Installation of Slide Bearing Housing Assembly

The slide bearing housing assembly will be installed during the installation of the slide assembly (par. 59a).

#### 58. Installation of Screw Assemblies

*a. Deflection. Boresight Adjusting Mechanism.* The screw assembly will be installed during the installation of the slide assembly (par 59b).

*b. Elevation Boresight Adjusting Mechanism.* The screw assembly will be installed during the installation of the holder assembly (par. 60d).

### Section VI. INSTALLATION OF ASSEMBLIES

#### 59. Installation of Slide Assembly

*a. Install slide bearing housing assembly (fig. 10).*

(1) Position key (N,5) in keyway in housing (N,6) and secure with No. 4 x 5/8 socket-head cap screw.

(2) Position key (W) in keyway in housing (N,6) and secure with No. 4 x 5/8 panhead screw and No. 4 lock washer.

(3) Attach ring (T) with six No. 4 x 3/8

fillister-head screws (S) to housing (N,6). Apply sealing compound.

(4) Install dust-moisture seal boots (Q) by fitting the smaller diameter flanges into the grooves of the slide assembly (R).

(5) Install slide assembly (R) into base housing assembly (N), engaging keyway in sleeve bushing over key (W) and fitting the outer flange of boot into groove formed by ring (T) and base housing assembly (N).

- (6) Insert expansion plug (P) into slide bearing housing assembly (N,7).
- (7) Install slide bearing housing assembly (N,7) over free end of slide assembly (R), engaging key way in housing (N,7a) over key (N,5) and fitting the outer flange of boot into groove in slide bearing housing assembly to base housing with two 3/8 x 1 1/2 hexagon-head cap screws (N,1), 3/8-inch lockwashers (N,2), and 3/8-inch flat washers (N,3).

b. Install deflection boresight adjusting mechanism (fig. 10).

- (1) Lubricate packing (F) lightly and install on lubricated retainer (G).
- (2) Lubricate packing (K) lightly and install on lubricated screw assembly (L).
- (3) Lubricate flat washer (H) and insert in retainer (G). Lubricate bearings

(J) and place one on each side of flange of screw assembly (L). Position screw assembly, with bearings, in retainer.

- (4) Lubricate flat washer (M), position against bearing and insert assembled parts into housing assembly (N), engaging the threaded portions of screw assembly (L) and slide assembly (R).
- (5) Using spanner wrench (fig. 5), screw retainer into base housing assembly (N) until it bottoms. Rack retainer off one-quarter turn and secure with two No. 10 x 1/4 hexagon-head set-screws (X), applying sealing compound.
- (6) Using spring wrench (fig. 12), install spring (D) in knob (B) and insert spring and knob in scale dial (E). Position knob, with scale dial and

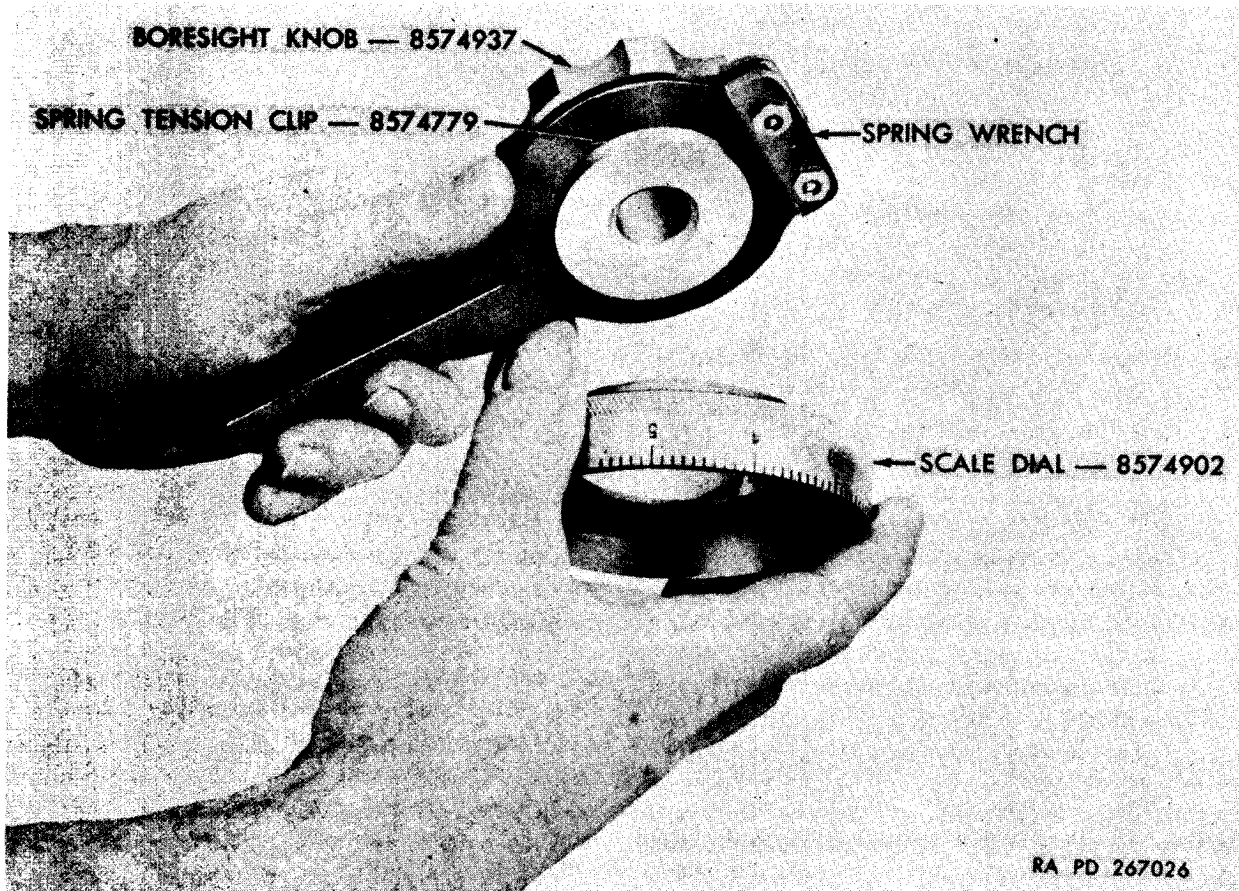

Figure 12. Compressing spring tension clip with spring wrench.

spring attached, alining hole in knob with corresponding hole in shaft of screw assembly.

- (7) Secure knob with No. 10 x  $\frac{3}{4}$  hexagon-socket setscrew and No. 3/0 x 1  $\frac{7}{16}$  tapered pin.

#### 60. Installation of Holder Assembly

##### a. Install key (fig. 8).

(1) Position key (T) in keyway in slide assembly (JJ).

(2) Secure key with No. 4 x  $\frac{3}{8}$  panhead screw (R) and No. 4 lockwasher (Q).

##### b. Lubricate packing (L) and install on lubricated holder (M, 9).

c. Position holder assembly in slide assembly (P), engaging keyway in holder over key (T) in slide assembly (P).

d. Install elevation boresight adjusting mechanism (fig. 8). Follow procedure for deflection boresight adjusting mechanism using parts (U) through (FF) in figure 8 (par. 59b).

Install deflection locking mechanism (fig. 8)

8)

(1) Lubricate wedge (K) lightly and in-

sert in housing assembly (GG), placing the flat surface formed by the right angle on the flat section of the slide assembly (P).

(2) Install plug (N) until it bottoms.

(3) Lubricate stud (J), shaft (H), packing (G), and washer (F) lightly and install these parts in housing assembly (GG). Washer should be flush with face of housing. If not, screw shaft onto stud until this condition exists.

(4) Position cover (E) and secure with four No. 8 x  $\frac{5}{8}$  panhead screws (C) and No. 8 lockwashers (D), applying sealing compound.

(5) Place lock lever (B) on splined portion of shaft (H) and lock parts by turning lever clockwise. With parts locked, remove lever and install in the down position as shown on figure 2. Secure lever with nut (A).

f. Install elevation locking mechanism (fig. 8). Follow procedure for deflection locking mechanism (*e* above).

### Section VII. TEST AND ADJUSTMENT OF TELESCOPE MOUNT M114 (T199)

#### 61. General

Tests and adjustments are performed after telescope mount M114 (T199) has been completely assembled.

#### 62. Set-up of Improvised Testing Device

Install the telescope mount securely in improvised testing device (fig. 13).

#### 63. Movement

a. Using the deflection boresight knob, position the holder at its midpoint of travel in deflection. Slip the deflection dial scale to the 3 position in coincidence with the index. Using the elevation boresight knob, position the holder at the extreme lowest point of its elevation travel. Slip the elevation scale to the 1 position.

b. The deflection boresight knob shall provide a minimum of 20 roils movement in each direction and the elevation boresight knob shall provide a minimum of 40 roils in elevation, as read on the respective scale, backlash excluded.

#### 64. Boresight Knob Torque

Using torque wrench adapter (fig. 6) with standard inch-pound torque wrench (fig. 14), rotate each boresight adjusting knob through full excursion. Torque requirements for rotation of the boresight knobs through full excursion should not exceed 8 inch-pounds and the slip scales must be movable at room temperature.

#### 65. Backlash

Backlash in elevation and deflection boresight movement should not exceed 0.1 mil. If backlash is excessive, a thicker shim must be installed in the screw assembly (par. 53).

#### 66. Deflection and Elevation Lock Levers

Position lock levers in locked position. Using torque wrench adapter (fig. 6) with standard inch-pound torque wrench (fig. 14), apply a 20-inch-pound torque to each boresight knob. This torque should not cause any movement in deflection and elevation. Locking and unlocking the boresight locking mechanism should not change the deflection and elevation alinement



of the telescope mount. When locking mechanisms are loosened, the deflection and elevation adjusting mechanisms should not move.

67. Holder Assembly

Install and clamp into the holder a telescope having a spherical mounting surface of 3.106

inches diameter. The assembly should remain rigid. Apply a force of 5 pounds parallel to the longitudinal axis of the spherical surface. The clamp screw should not be adversely affected by this test. Removal of the telescope from the holder should be without restriction.

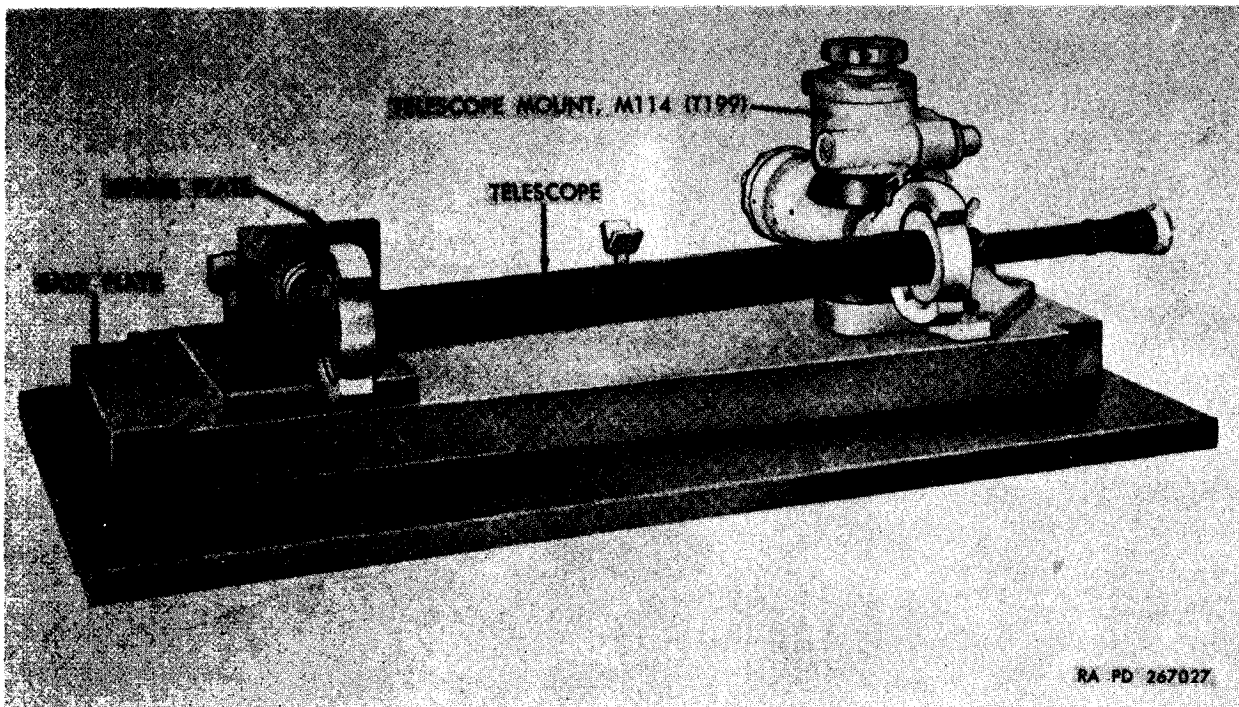
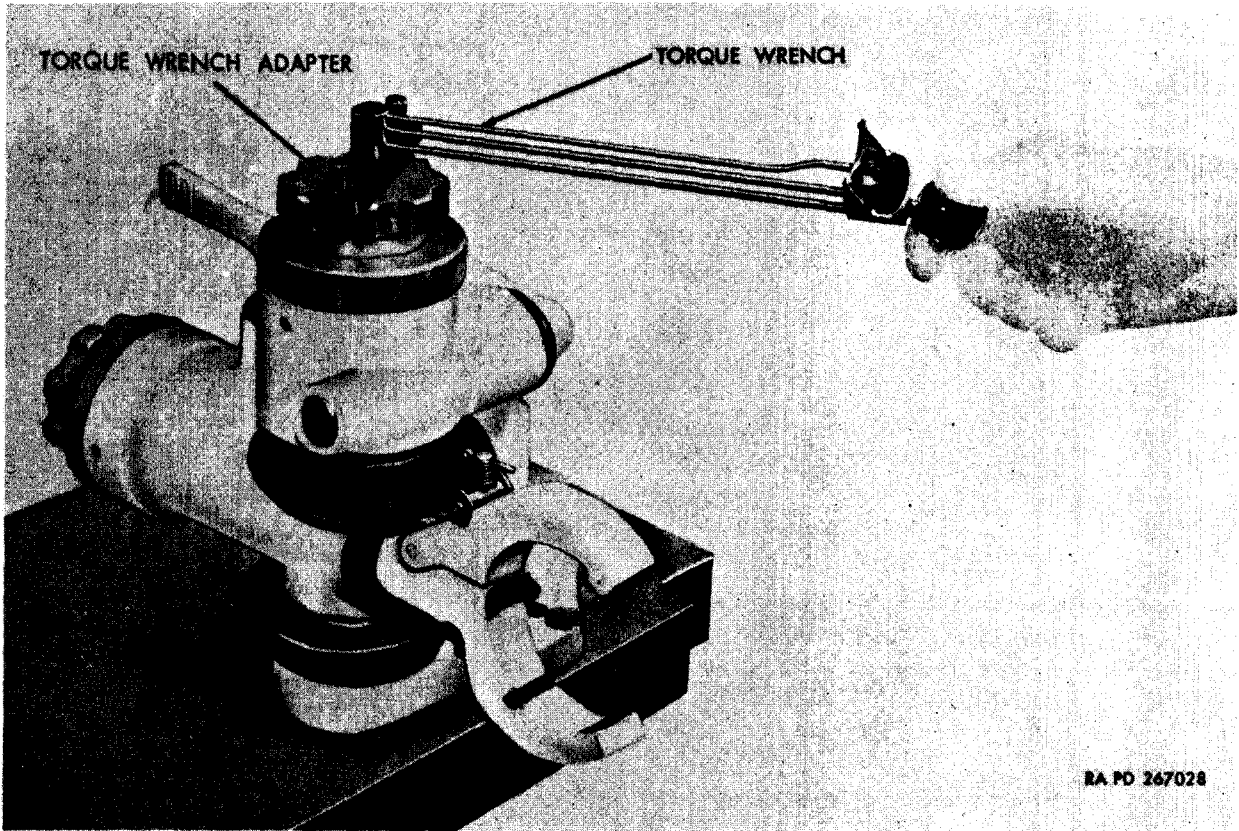

Figure 13. Improvised testing device.



*Figure 14. Torque wrench adapter.*

## CHAPTER 8

### FINAL INSPECTION

---

#### 68. General

Final inspection is performed after repair or rebuild has been completed to insure that the material is serviceable according to established serviceability standards. Any items containing defects disclosed by the final inspection will be returned to the shop for repair or adjustment.

#### 69. Visual Inspection

Visually inspect telescope mount in accordance with paragraphs 12 through 21.

#### 70. Final Inspection for Acceptance

Final inspection for acceptance is made to assure that proper finish and performance of telescope mount M114 (T199) is in accordance with specifications and rebuild standards.

*a. Movement.* The deflection boresight knob shall provide a minimum of 20 roils movement in each direction when the deflection dial scale is in the 3 position. The elevation boresight knob shall provide a minimum of 40 roils move-

ment in elevation when the elevation dial scale is in the 1 position (par. 63).

*b. Boresight Knob Torque.* Torque requirements for rotation of the boresight knobs through full excursion shall not exceed 8 inch-pounds and the slip scales shall be movable at room temperature (par. 64).

*c. Backlash.* Backlash in elevation and deflection boresight movement shall not exceed 0.1 mil (par. 65).

*d. Lock Levers.* Locking and unlocking boresight locking mechanism shall not change the deflection and elevation alinement of the telescope mount. Application of a 20-inch-pound torque to each boresight knob shall not cause movement in deflection and elevation. When the locking levers are in the unlocked position, the adjusting mechanism shall not move (par. 66).

*e. Holder Assembly.* The clamp screw shall not be adversely affected when a force of 5 pounds is applied parallel to the longitudinal axis of the spherical surface of the telescope installed in the holder assembly (par. 67).

## CHAPTER 9

### INSTALLATION OF TELESCOPE MOUNT M114 (T199)

---

#### Section I. INSTALLATION

##### 71. General

This chapter provides instructions for the installation of the telescope mount M114 (T199) in the 105-mm gun full-tracked combat tank M60 by Ordnance field maintenance personnel.

##### 72. Installation of Telescope Mount M114 (T199)

*a.* Drive two locating pins into the gun mounting surface.

*b.* Position the telescope mount on the gun mounting surface, aligning the pin holes in the mount with the pins in the mounting surface. Center pin in elongated hole. Using a soft mallet or other suitable tool, drive the pins into the pin holes.

*c.* Secure telescope mount with five  $\frac{1}{2}$  x  $1\frac{1}{2}$  hexagon-head cap screws,  $\frac{1}{2}$ -inch flat washers, and  $\frac{1}{2}$ -inch lock washers.

#### Section II. ADJUSTMENT

##### 73. Adjustment of Installed Telescope Mount M114 (T199)

*a.* Install serviceable articulated telescope M105C in accordance with instructions in TM 9-2350-215-20.

*b.* Boresight on a 1500-meter target. Using

the elevation boresight knob, position the holder at its midpoint of travel in elevation. The elevation boresight adjusting knob shall provide a minimum of 20 mils movement in each direction as indicated on test target.

*c.* To correct position of mount, loosen screws and reposition pin in elongated hole.

**CHAPTER 10**  
**PROCESSING AND PACKAGING**

---

74. General

For instructions for processing and packaging telescope mount M114 (T199), refer to

packaging specifications MIL-M-45125 (Ord), TM 9-200 (boxed materiel), and TB 9-299 (unboxed materiel).

## APPENDIX REFERENCES

### 1. Publication Indexes

The following indexes should be consulted frequently for the latest changes or revisions of reference given in this appendix and for new publications relating to materiel covered in this manual.

Index of Army Motion Pictures, Film Strips, Slides, and Phono-Recordings.	DA Pam 108-1
Military Publications:	
Index of Administrative Pub- lications.	DA Pam 310-1
Index of Blank Forms . . . . .	DA Pam 310-2
Index of Graphic Training Aids and Devices.	DA Pam 310-5
Index of Supply Manuals; Ordnance Corps.	DA Pam 310-29
Index of Tables of Organi- zations and Equipment, Tables of Organization, type Tables of Distribution, and Tables of Allowances.	DA Pam 310-7
Index of Technical Manuals, Technical Bulletins, Supply Bulletins, Lubrication Or- ders, and Modification Work Orders.	DA Pam 310-4
Index of Training Publica- tions.	DA Pam 310-3

### 2. Supply Manuals

The following manuals of the Department of Army supply manual pertain to this materiel.

#### *a. Destruction to Prevent Enemy Use.*

Ammunition: Explosives, Bulk SM 9-5-1375  
Propellants, and Explosive  
Devices.

#### *b. General.*

Introduction . . . . .ORD 1

#### *c. Repair and Rebuild.*

Brushes, Paints, Sealers and  
Adhesives. SM 9-1-8000

Fuels, Lubricants, Oils, and  
Waxes. SM 9-1-9100

Special Tool Sets for Sighting  
and Fire Control Materiel  
ORD (\*) SNL J-32

used with Small Arms, Auto-  
matic Guns, Mortars and  
Field Artillery (SNL Group  
F).

Tool Kit, Fire Control Repair- SM 9-4-5180-A61  
man (5180-357-7735).

Tool Kit, Instrument Repair- SM 9-4-5180-A62  
man's (Ord Dwg No. 7540666)  
(MOS 403.20) (5180-357-  
7743).

### 3. Forms

The following forms pertain to this materiel:

DA Form 5-31, Shop Job Order Register
DA Form 9-79, Part Requisition
DA Form 9-80, Job Order File
DA Form 9-81, Exchange Part or Unit Identification Tag
DA Form 421, Stock Record Card
DA Form 468, Unsatisfactory Equipment Report
DA Form 828, Job Time Ticket - Individual
DA Form 829, Rejection Memorandum
DA Form 1546, Request for Issue or Turn-in
DA Form 2028, Recommended Changes to DA Techni- cal Manual Parts List or Supply Manual 7, 8, or 9
DD Form 6, Report of Damaged or Improper Shipment

### 4. Other Publications

#### *a. Camouflage.*

Camouflage, Basic Principles FM 5-20  
and Field Camouflage.

#### *b. Decontamination.*

Decontamination . . . . . TM 3-220

Small Unit Procedures in FM 21-40  
Atomic, Biological, and Chem-  
ical Warfare.

#### *c. Destruction to Prevent Enemy Use.*

Explosives and Demolitions . . . . . FM 5-25

Ordnance Ammunition Service . . . . . FM 9-5

Ordnance Service in the Field . . . . . FM 9-1

Safety: Regulations for Firing AR 385-63  
Ammunition for Training, AFR 50-13  
Target Practice and Combat.

#### *d. General.*

All Combat Vehicles: Failure of TB ORD 548  
Azimuth Indicators, Sighting  
and Fire Control Instruments.

(\*) See DA Pam 310-29, Index of Supply Manuals; Ordnance Corps, for published types of manuals of the Ordnance section the Army supply manuals.

Logistics (General): Malfunctions Involving Ammunition and Explosives.	AR 700-1300-8	ing Chemical, Lubricants, Indicators, and Hydraulic Fluids.	
Logistics (General): Unsatisfactory Equipment Report.	AR 700-38	Organizational Maintenance: 105-mm. Gun, Full-Tracked Combat Tank, M60.	TM 9-2350-215-20
Military Symbols .....	FM 21-30 AFM 55-3	Organizational Maintenance Repair Parts and Special Tools List for 105-mm Gun, Full-Tracked Combat Tank, M60: Organizational Maintenance.	TM 9-2350-215-20P
Military Terms, Abbreviations and Symbols:		Painting Instructions for Field Use.	TM 9-2851
Authorized Abbreviations and Brevity Codes.	AR 320-50	Solder and Soldering .....	TB SIG 222
Dictionary of United States Army Terms.	AR 320-5	Special Operations: Northern Operations.	FM 31-71
Military Training .....	FM 21-5	Welding Theory and Application	TM 9-237 TO 34W4-1-5
Safety: Accident Reporting and Records.	AR 385-40	<i>f. Operation.</i>	
Shop Mathematics .....	TM 9-2820	Artillery Materiel and Associated Equipment.	TM 9-2300
Techniques of Military Instruction.	FM 21-6	Auxiliary Sighting and Fire Control Equipment.	TM 9-575
<i>e. Maintenance.</i>		Operation: 105-mm Gun, Full-Tracked Combat Tank, M60.	TM 9-2350-215-10
Field and Depot Maintenance Repair Parts and Special Tool Lists for Telescope Mount M114 (T199).	TM 9-1240-285-35P	<i>g. Shipment and Storage.</i>	
Fire Control Materiel: Lubrication.	TM 9-2835-1	General Packaging Instructions for Ordnance General Supplies.	TM 9-200
General Maintenance Procedures for Fire Control Materiel.	TM 9-254	Instruction Guide: Ordnance Preservation, Packing, Packaging, Storage and Shipping.	TM 9-1005
Inspection of Ordnance Materiel in Hand of Troops.	TM 9-1100	Issue of Supplies and Equipment: Preparation, Processing, and Documentation for Requisitioning, Shipping, and Receiving.	AR 725-5
Instruction Guide: Elementary Optics and Applications to Fire Control Instruments.	TM 9-2601	Logistics (General): Report of Damaged or Improper Shipment.	AR 700-58
Maintenance and Care of Hand Tools.	TM 9-867	Marking and Packing of Supplies and Equipment: Marking of Supplies for Shipment.	AR 746-80
Maintenance of Supplies and Equipment:		Protection of Ordnance General Supplies in Open Storage.	TB ORD 379
Command Maintenance Inspection.	AR 750-8	Standards for Oversea Shipment and Domestic Issue of Ordnance Materiel Other than Ammunition and Army Aircraft.	TB ORD 385
Spot Check Inspection and Reports, Ordnance Corps Materiel.	AR 750-925	Storage and Shipment of Supplies and Equipment: Preservation, Packaging and Packing.	AR 740-15
Operation and Maintenance of Ordnance Materiel in Extreme Cold Weather, 0° to -65° F.	TM 9-207	Storage of Supplies and Equipment: Storage and Materials Handling.	TM 743-200-1
Ordnance Direct Support Service.	FM 9-3		
Ordnance General and Depot Support Service.	FM 9-4		
Ordnance Maintenance: Materials Used for Cleaning, Preserving, Abrading, and Cementing Ordnance Materiel and Related Materiel Includ-	TM 9-1007		

# INDEX

	Paragraph	Page		Paragraph	Page
Acceptance inspection (See Inspection, final)			Holder assembly:		
Accidents, report of . . . . .	3c	5	Assembly . . . . .	51d	26
Adjusting mechanism, deflection and elevation (See Boresight adjusting mechanism)			Cleaning and inspection . . . . .	51b	26
Adjustment, deflection scope of . . . . .	7,63	8,30	Description . . . . .	6b(3)	5,8
Adjustment, elevation scope of . . . . .	7,63	8,30	Disassembly . . . . .	51a	26
Alinement after installation . . . . .	72	34	Inspection, final . . . . .	67	31
Allocation and parts, maintenance . . . . .	2	3	Installation . . . . .	60	30
Backlash check . . . . .	65	30	Rebuild . . . . .	51	26
Boot, seal, dust-moisture, replacement . . . . .	30	19	Rebuild standards . . . . .	51c	26
Boresight adjusting mechanism:			Reclamation techniques . . . . .	51b	26
Description . . . . .	6b(4)	5,8	Removal . . . . .	43	21
Replacement . . . . .	31,32	20	Repair . . . . .	34	20
Test, performance . . . . .	19c	13	Tests and adjustments . . . . .	51e	26
Boresight locking mechanism:			Housing assembly (base) . . . . .	6b(1)	5,8
Description . . . . .	6b(5)	5,8	Identification plate:		
Replacement . . . . .	33	20	Installation . . . . .	55	28
Test, performance . . . . .	19b	13	Removal . . . . .	49	26
Cleaning . . . . .	38	21	Initial inspection . . . . .	14c	12
Command maintenance inspection (See Maintenance, command inspection)			In-process inspection . . . . .	14d	12
Common tools and equipment (See Tools and equipment)			Inspection:		
Components, main, description . . . . .	6b	5	Backlash . . . . .	65	30
Deflection and elevation boresight lock levers . . . . .	6b(5)	5,8	Boresight knob torque . . . . .	64	30
Holder assembly . . . . .	6b(3)	5,8	Categories:		
Housing assembly (base) . . . . .	6b(1)	5,8	Command maintenance . . . . .	14b	12
Scale dials and boresight knobs . . . . .	6b(4)	5,8	Final . . . . .	14e	13
Slide assembly . . . . .	6b(2)	5,8	Initial . . . . .	14c	12
Data . . . . .	7	8	In-process . . . . .	14d	12
Decals, elevation and deflection:			Spot check . . . . .	14a	12
Installation . . . . .	54	28	Field maintenance . . . . .	20,21	14
Removal . . . . .	50	26	Final:		
Deflection and elevation adjusting mechanism, repair . . . . .	31	20	Acceptance . . . . .	70	33
Depot maintenance (See Maintenance, depot)			General . . . . .	68	33
Description, general . . . . .	5,6a	5	Visual . . . . .	69	33
Dials, scale . . . . .	6b(4)	5,8	Holder assembly . . . . .	67	31
Equipment and tools (See Tools and equipment)			In hands of troops . . . . .	15-18	13
Fabricated tools (See Tools and equipment)			Lock lever, deflection . . . . .	66	30
Field maintenance (See Maintenance, field)			Lock lever, elevation . . . . .	66	30
Final inspection (See Inspection, final)			Movement . . . . .	63	30
Flat-rate time (See Time, flat-rate)			Performance test . . . . .	19	13
Flow chart, rebuild . . . . .	4a	5	Purpose . . . . .	13	12
Forms:			Rebuild . . . . .	37	21
Authorized . . . . .	3b	3	Scope . . . . .	12	12
Records and reports . . . . .	3,16	3	Installation, telescope mount . . . . .	71-73	35
			Knob, boresight (See Boresight adjusting mechanism)		
			Lever, boresight lock, deflection (See Boresight locking mechanism)		
			Lever, boresight lock, elevation (See Boresight locking mechanism)		
			Loop clamp assembly:		
			Description . . . . .	6b(1)	5,8
			Installation . . . . .	56	28
			Removal . . . . .	48	26
			Replacement . . . . .	35	20
			Test, performance . . . . .	19a	13
			Maintenance, command inspection . . . . .	14b	12



	Paragraph	Page		Paragraph	Page
Maintenance, depot .....	2b, 2d	3	Screw assembly—Continued:		
Flow chart, rebuild .....	4a	5	Removal .....	46	25,26
Inspection .....	14b	12	Tests and adjustments .....	53a(5)	28
Inspection, initial .....	14c	12	Shim, backlash correcting .....	65	30
Inspection, in-process .....	14d	12,13	Slide assembly:		
(Also see Allocation and parts, maintenance)			Assembly .....	52d	28
Maintenance, field .....	2a	3	Cleaning and inspection .....	52b	27
Inspection .....	14a	12	Description .....	6b(2)	8
Inspection, initial .....	14c	12	Disassembly .....	52a	27
Inspection, in-process .....	14d	12,13	Installation .....	59	28
Inspection, shop .....	20,21	14	Rebuild .....	52	27
Repair, scope .....	28	19	Rebuild standards .....	52c	27
Tools, fabricated .....	11a	10	Removal .....	44	25
(Also, see Allocation and parts, maintenance)			Repair .....	30	19
Packaging and Packing .....	74	35	Test and adjustments .....	52e	28
Performance test (See Test, perform- ance)			Special tools and equipment (See Tools and equipment)		
Rebuild:			Spot-check inspection .....	14a	12
Flow chart .....	4a	5	Tables:		
Scope .....	36	21	Fabricated tools (table III) .....	11a	11
(See also specific item)			Main assemblies and sequence of removal (table V) .....	42	21
Rebuild standards:			Main assemblies of telescope mount M114 (T199) (table II) .....	5	5
Holder assembly .....	51c	26	Operations route sheet for tele- scope mount M114 (T199) (table I) .....	4b	5
Screw assembly .....	53c	28	Removal of subassemblies (table VI) .....	46	25,26
Slide assembly .....	52c	26	Troubleshooting (table IV) .....	23	15
Rebuild time (See Time, rebuild)			Telescope mount installation (See In- stallation, telescope mount)		
Reclamation techniques			Test, performance .....	19	13
Holder assembly .....	51b	26	Testing device, initial set-up .....	62	30
Screw assembly .....	53b	28	Tests and adjustments:		
Slide assembly .....	52b	26	Holder assembly .....	51e	27
References .....	1c	3	Installation .....	73	34
Removal:			Screw assembly .....	53a(5)	28
Extent .....	25	17	Slide assembly .....	52e	28
Procedure .....	26	17	Time, flat-rate:		
Scope .....	24	17	Rebuild .....	37	21
(See also specific items)			Removal .....	27	17
Repair:			Time, rebuild .....	2c	3
References .....	29	19	Tools and equipment:		
Scope .....	28	19	Common .....	9	11
(See also specific item)			Fabricated .....	11a	11
Reports (See Forms, records, and reports)			General .....	8	11
Route sheet, operations .....	4b	5	Improvised .....	11b	11
Scale dials (See Dials, scale)			Special .....	10	11
Scope:			Torque requirement:		
Inspection .....	12	12	Boresight knob .....	64	30
Instructions, general .....	1	3	Boresight lock lever .....	66	30,31
Rebuild .....	40	21	Troubleshooting:		
Removal .....	24	17	Purpose .....	22	15
Repair .....	28	19	Scope .....	23	15
Troubleshooting .....	23	15	Unsatisfactory equipment or mater- ials, report of .....	3d	5
Screw assembly:			Visual inspection (See Inspection, final)		
Assembly .....	53a(4)	28	Work orders, modification .....	17	13
Cleaning and inspection .....	53a(2)	28			
Disassembly .....	53a(1)	28			
Installation .....	58	28			
Rebuild .....	53	28			
Rebuild standards .....	53a(3)	28			
Reclamation techniques .....	53a(2)	28			

By Order of *Wilber M. Brucker*, Secretary of the Army:

**L. L. LEMNITZER,**  
*General, United States Army,*  
*Chief of Staff.*

**Official:**

**R. V. LEE,**  
*Major General, United States Army,*  
*The Adjutant General.*

**Distribution:**

*Active Army:*

To be distributed in accordance with DA Form 12-7 requirements for TM 9 Series (UNCL) plus the following formula:

	Units org under fol TOE (2 copies each):	
DCSLOG (1)	9-7	9-66
Tech Stf, DA (1) except	9-9	9-67
CofOrd (9)	9-12	9-76
US ARADCOM (2)	9-25	9-167
US ARADCOM Rgn (2)	9-26	9-367
Seventh USA (3)	9-57	9-500
EUSA (3)	9-65	9-510
Corps (2)		
Raritan Arsenal (33)		

NC: State AG (3); TOE Units (1 copy each):

9-7	9-27	9-67	9-510
9-9	9-28	9-76	
9-12	9-57	9-127	
9-26	9-66	9-197	

*USAR: None.*

For explanation of abbreviations used, see AR 320-50.



PIN : 026600-000